

JUMO variTRON 300

Automation System

Central Processing Unit



Operating Manual



70500300T90Z001K000

V12.00/EN/00748411/2026-04-08

Further information and downloads



jmo.to/705003-en

Table of contents

1	Introduction	6
1.1	Safety information	6
1.2	Trademark information	7
1.3	Intended use	7
1.4	Qualification of personnel	7
1.5	Security	7
1.6	Acceptance of goods, storage, and transport	8
1.6.1	Checking the delivery	8
1.6.2	Important information about storage and transport	8
1.6.3	Returning goods	8
1.6.4	Disposal	9
1.7	Module overview	10
1.7.1	Central processing unit	10
1.7.2	Modules	11
1.8	Available technical documentation	15
1.8.1	Central processing unit	15
1.8.2	Input/output modules	15
1.8.3	Special modules	16
1.8.4	Panels	17
1.8.5	Power supply units	17
1.9	System version	18
1.10	Declaration of conformity	18
2	Description	19
2.1	Identifying the device version	21
2.1.1	Nameplate	21
2.1.2	Order details	22
2.1.3	Scope of delivery	23
2.1.4	Accessories	24
2.2	Device functions	25
2.3	Software	26
3	Mounting	27
3.1	General information on installation/dismounting	27
3.2	Installation/dismounting on DIN rail	28
3.2.1	Central processing unit	29
3.3	Dimensions	31
4	Electrical connection	32
4.1	Installation notes	32
4.2	Electrical isolation	33

Table of contents

4.3	Connection diagram	33
4.3.1	Display, operating, and connection elements	34
4.3.2	Voltage supply	35
4.3.3	Interfaces	35
4.3.4	Terminating resistors	36
5	Operation	37
5.1	General information	37
5.2	Device	38
5.2.1	Display and control elements	38
5.2.2	Device menu	39
5.2.3	User log-on	43
5.2.4	Reset to factory settings	43
5.3	Setup program	44
5.3.1	Start page	44
5.3.2	Project map	45
5.3.3	Project management	46
5.3.4	System bus HW assistant	47
5.3.5	Optional module (alias device address)	49
5.3.6	Wtrans HW assistant	51
5.3.7	Configuration	53
5.3.8	PLC application	55
5.3.9	PLC parameter definition	56
5.3.10	Languages	57
5.3.11	Data transfer	59
5.3.12	Messages	63
5.3.13	Connections	64
5.4	Web Services	66
5.4.1	Web Cockpit	67
5.4.2	CODESYS WebVisu/Remote TargetVisu	81
5.4.3	Other apps	81
5.5	JUMO smartWARE Evaluation	82
6	Configuration	83
6.1	General information	83
6.2	Network	85
6.2.1	Ethernet	85
6.2.2	Port configuration	85
6.3	Device manager	86
6.3.1	Customer-specific linearization	87
6.3.2	Display	88
6.4	Unit settings	89
6.5	System bus	91
6.6	Data carrier management	93

Table of contents

6.7	System status UI	.94
6.8	Web server	.94
6.9	Email	.95
6.10	PLC configuration	.96
6.10.1	Program generator	.96
6.10.2	Analog variables	.100
6.10.3	Digital variables	.100
6.11	PLC parameters	.100
6.12	Programs	.101
6.13	CODESYS configuration	.103
6.14	Recorder	.104
6.15	Recording data export	.108
6.16	Cloud gateway	.109
6.17	Signal generator	.110
6.18	Wtrans gateway	.111
6.19	Node-RED	.112
6.20	Batches	.113
6.20.1	Batches	.113
6.20.2	Text lists	.115
6.21	UI resources	.115
6.22	App management	.115
7	Startup	.116
8	Annex	.123
8.1	User rights	.123
8.1.1	System version 7	.123
8.1.2	System version 8	.125
8.1.3	System version 9	.130
8.1.4	System version 10	.136
8.2	Technical data	.142
8.2.1	Interfaces	.142
8.2.2	Display	.144
8.2.3	Electrical data	.144
8.2.4	Housing and environmental conditions	.145
8.2.5	Approval marks and certificates	.145
8.3	PLC data	.146
8.3.1	System times	.146
8.3.2	IEC tasks	.149
8.3.3	Memory for customer-specific PLC programs	.150
8.4	Buffer battery replacement	.151
8.5	Open-source software	.154
8.6	China RoHS	.155

1 Introduction

1.1 Safety information

General

This manual contains information that must be observed in the interest of your own safety and to avoid material damage. This information is supported by symbols which are used in this manual as indicated.

Please read this manual before starting up the device. Store this manual in a place that is accessible to all users at all times.

If difficulties occur during startup, please do not intervene in any way that could jeopardize your warranty rights!

Warning symbols



WARNING!

This symbol in connection with the signal word indicates that **personal injury** may occur if the respective precautionary measures are not carried out.



CAUTION!

This symbol in connection with the signal word indicates that **material damage or data loss** will occur if the respective precautionary measures are not taken.



CAUTION!

This symbol indicates that **components could be destroyed** by electrostatic discharge (ESD = Electro Static Discharge) if the respective cautionary measures are not taken.

Only use the ESD packages intended for this purpose to return device inserts, assembly groups, or assembly components.



READ THE DOCUMENTATION!

This symbol, which is attached to the device, indicates that the associated **documentation for the device** must be **observed**. This is necessary to identify the nature of the potential hazard, and to take measures to prevent it.

Note symbols



NOTE!

This symbol refers to **important information** about the product, its handling, or additional benefits.



REFERENCE!

This symbol refers to **additional information** in other sections, chapters, or other manuals.



FURTHER INFORMATION!

This symbol is used in tables and indicates that **further information** is provided after the table.



DISPOSAL!

At the end of its service life, the device and any batteries present do not belong in the trash! Please ensure that they are **disposed of** properly and in an **environmentally friendly** manner.

1.2 Trademark information

All trademarks and trade and company names used are the property of their rightful owners or authors.

1.3 Intended use

The device is designed for use in an industrial environment as specified in the technical data. Other uses beyond those defined are not viewed as intended uses.

The device has been manufactured in compliance with applicable standards and directives as well as the applicable safety regulations. Nevertheless, improper use may lead to personal injury or material damage.

To avoid danger, only use the device:

- For the intended use
- When in good order and condition
- When taking the technical documentation provided into account

Risks resulting from the application may arise, e.g. as the result of missing safety provisions or wrong settings, even when the device is used properly and as intended.

1.4 Qualification of personnel

The personnel deployed must meet the following requirements in all phases of the product lifecycle:

- Trained electrical, mechanical, and plant engineering personnel.
- Members of personnel are familiar with this documentation and the safety information and warnings it contains.

1.5 Security

The manufacturer only provides a warranty if the device is installed and used as described in this documentation. This device is equipped with security mechanisms that protect it against accidental changes to the device settings. Security measures that meet the operator's security standards and offer additional protection for the device and device data transmission must be applied by the operator themselves.

Reference is made to the Security Manual here, which regulates the following points:

- Intended use with regards to security
- Organizational measures regarding the handling of security measures by the operator
- Organizational measures by the manufacturer

⇒ JUMO variTRON 300 Security Manual – 70500000T95Z000K000

1 Introduction

1.6 Acceptance of goods, storage, and transport

1.6.1 Checking the delivery

- Ensure that the packaging and its contents are undamaged.
- Check the delivery for completeness against the packing slip and order details.
- Inform the supplier immediately if there is any damage.
- Store damaged parts until clarification is received from the supplier.

1.6.2 Important information about storage and transport

- Store the device in a dry, clean environment. Observe the admissible ambient conditions (see "Technical data")
- Protect the device from shock during transport
- The original packaging provides optimum protection for storage and transport

1.6.3 Returning goods

If repairs are needed, return the complete device in clean condition.
Use the original packaging to return goods.

Accompanying letter for repair

Please include the completed accompanying letter for repair when returning goods.

Do not forget to state the following:

- Description of the application and
- Description of the error that has occurred

The accompanying letter for repair (supplementary sheet for product returns) can be downloaded online from the manufacturer's website:

<http://productreturn.jumo.info>

Protection against electrostatic discharge (ESD)

(ESD = electrostatic discharge)

To prevent damage due to ESD, electronic modules or components must be handled, packaged, and stored in an ESD-protected environment. Measures that protect against electrostatic discharge and electric fields are described in DIN EN 61340-5-1 and DIN EN 61340-5-2 "Protection of electronic devices from electrostatic phenomena".

When sending back electronic modules or components, please note the following:

- Pack sensitive components only in an environment providing protection against ESD. Workspaces such as this divert electrostatic charges to ground in a controlled manner and prevent static charges due to friction.
- Use only packaging intended specifically for ESD-sensitive modules/components. These must consist of conductive plastics.

No liability can be assumed for damage caused by ESD.



CAUTION!

Electrostatic charges occur in non-ESD-protected environments.

Electrostatic discharges can damage modules or components.

- ▶ For transport purposes, use only the ESD packaging provided.
-

1.6.4 Disposal

Disposing of the packaging material

The entire packaging material (cardboard packaging, inserts, plastic film, and plastic bags) is fully recyclable.

The country-specific laws and regulations for waste treatment and disposal must be observed.

Disposing of the device



DISPOSAL!

Devices and/or replaced parts (including batteries) should not be placed in the refuse bin at the end of their service life, but must be disposed of properly and in an environmentally friendly manner.

The device consists of materials that can be recycled by specialist recycling plants.

The country-specific laws and regulations for waste treatment and disposal must be observed.

1 Introduction

1.7 Module overview

1.7.1 Central processing unit

The central processing unit JUMO variTRON 300 along with the proven input and output modules (incl. controller module) as well as the router modules (primarily router module 1-port, 705043) form an overall system.

The central processing unit manages all configuration and parameter data in the overall system and makes a PLC available according to IEC 61131-3 (CODESYS V3.5) (extra code 224).

The PLC can be activated in different versions:

- CODESYS runtime system incl. CODESYS Remote TargetVisu and/or
- CODESYS Remote TargetVisu (extra code 280) and/or
- CODESYS WebVisu (extra code 281)

Commercially available panels that support the CODESYS Remote TargetVisu or CODESYS WebVisu functionality can be used for visualization. "Remote Target Visu" is required so that the central processing unit can provide the screen for the panel with "Remote Target Visu". Visualization is also possible via web browser. Visualizations have to be implemented with CODESYS resources.

An easy-to-use setup program is used for configuration. JUMO standard functions for CODESYS are provided in libraries (as of system version 6) and can be individually integrated into the customer application.

As from system version 5, the JUMO variTRON 300 central processing unit will be available as a receiver for JUMO Wtrans transmitters, thereby enabling wireless measured value transmission.

Module designation	Data sheet	Features
JUMO variTRON 300 Central processing unit	705003	<ul style="list-style-type: none">• Process mapping for all connected input/output modules (incl. controller modules)• Display and keys to display the system status• USB host interface• OPC UA server (in conjunction with PLC)• Field bus interface (RS485; Modbus RTU in conjunction with PLC)• PROFINET IO controller (in conjunction with PLC)• Plug and Play for input/output module replacement• Battery-buffered real-time clock• Data evaluation with JUMO smartWARE Evaluation (as of system version 6)

1.7.2 Modules

The proven controller, input or output modules from the article group 7050xx, and the new generation of the JUMO I/O system 7051xx are available as module variants. These include the analog input module with universal inputs for thermocouples, RTD temperature probes, and voltage or current standard signals. As a result, the same hardware can be used to precisely acquire and digitize a highly diverse range of process variables.

JUMO variTRON 300 enables simultaneous operation of up to 32 control loops so that it can also be used for sophisticated processes. On JUMO variTRON controller modules (7050xx), the inputs and outputs of each controller module can be individually expanded and modified using the expansion slots. The control loops here operate fully independently, which means they do not require resources from the central processing unit. The JUMO I/O system (7051xx) controller modules do not have expansion slots.

As of system version 9, thyristor power controllers can be integrated with JUMO system bus and in the PLC (CODESYS) via EtherCAT or PROFINET.

In addition, JUMO digiLine sensors for liquid analysis can be connected to the central processing unit.

Wireless measured value transmission

As from system version 5, the JUMO variTRON 300 central processing unit is also available with a wireless interface that enables wireless transmission of measured values. The transmitters of the JUMO Wtrans series are available as measuring probes (Wtrans T, Wtrans B, Wtrans p, Wtrans E01 as of system version 6). A maximum of 32 transmitters can be operated on the central processing unit.

During startup, the display of the RSSI value (Received Signal Strength Indicator) in the Web Cockpit is helpful as an indicator of the signal strength of a received radio telegram.

Input/output modules - 7050xx JUMO variTRON

Module designation	Data sheet	Features
Multichannel controller module	705010	<ul style="list-style-type: none"> Up to 4 independently configurable PID control loops with a fast cycle time and proven control algorithms Independent operation Math and logic functions Counting input up to 10 kHz
Relay module 4-channel	705015	<ul style="list-style-type: none"> 4 relay outputs controlled via the system bus by digital signals Changeover contact in each case (230 V/3 A) Switching statuses are visualized with LEDs
Analog input module 4-channel	705020	<ul style="list-style-type: none"> 4 high-quality, user configurable analog inputs for RTD temperature probes, resistance transmitters, thermocouples, current 0(4) to 20 mA, voltage 0(2) to 10 V All inputs are galvanically isolated from each other Customer-specific linearization possible Limit value monitoring function Additional digital input
Analog input module 8-channel	705021	<ul style="list-style-type: none"> 8 high-quality analog inputs for RTD temperature probes Pt100, Pt500, Pt1000 in two-wire circuit Limit value monitoring function Additional digital input

1 Introduction

Module designation	Data sheet	Features
Analog output module 4-channel	705025	<ul style="list-style-type: none"> • 4 user configurable analog outputs 0(4) to 20 mA or 0(2) to 10 V • Adjustable output behavior in case a malfunction occurs
Digital input or output module 12-channel	705030	<ul style="list-style-type: none"> • 12 digital inputs or outputs • Each channel can be user configured as an input DC 0/24 V or output DC 24 V • Capacity per output: 500 mA • Switching statuses are visualized with LEDs
Digital input or output module 32-channel (as of system version 3)	705031	<ul style="list-style-type: none"> • 17 digital outputs • Up to 15 additional digital inputs or outputs • Capacity per output: 500 mA • Switching statuses are visualized with LEDs
Thyristor power controller type 70906x (as of system version 3)	709061, 709062, 709063	<ul style="list-style-type: none"> • For one-phase and three-phase operation • Continuous load current up to 250 A, load voltage up to 500 V • Different circuit variants, load types and operating modes can be implemented

I/O modules - 7051xx JUMO I/O system

Module designation	Data sheet	Features
Multichannel controller module	705152	<ul style="list-style-type: none"> • 2 variants • Up to 2 independently configurable PID control loops with a fast cycle time and proven control algorithms • Independent operation • PLC function due to ST code • Counting input up to 12.5 kHz
Analog input module 4-channel	705113	<ul style="list-style-type: none"> • 3 variants • 4 high-quality, user configurable analog inputs for RTD temperature probes, resistance transmitters, thermocouples, current 0(4) to 20 mA, voltage 0(2) to 10 V • All inputs are galvanically isolated from each other • Customer-specific linearization possible • Limit value monitoring function
Analog output module 4-channel	705123	<ul style="list-style-type: none"> • 4 user configurable analog outputs 0(4) to 20 mA or 0 to 10 V • Adjustable output behavior in case a malfunction occurs
Digital input module 16-channel	705135	<ul style="list-style-type: none"> • Digital signal DC 0/24 V • External voltage DC 24 V via potential-free contact • Max. 5 mA per input • Reference potential L- (GND) required

1 Introduction

Module designation	Data sheet	Features
Digital output module 4-channel	705143	<ul style="list-style-type: none">• External voltage supply DC 24 V SELV• Lateral supply via router module• 4 relay outputs (changeover contact)• Switching capacity<ul style="list-style-type: none">- 3 A at AC 230 V- 3 A at DC 30 V
Digital output module 16-channel	705145	<ul style="list-style-type: none">• External voltage supply DC 24 V SELV• Lateral supply via router module• Output signal DC 0/24 V• Max. 500 mA per output

Special modules - 7050xx JUMO variTRON

Module designation	Data sheet	Features
Router module 2-port (as of system version 3)	705041	<ul style="list-style-type: none">• Arrangement on DIN rail (lateral system bus input and output)• Is only intended for system bus expansion via RJ45 sockets on the front (2 × Bus Out)
Router module 3-port (as of system version 3)	705042	<ul style="list-style-type: none">• Use as first module on an additional DIN rail for connecting further modules (system bus input via RJ45 socket; system bus output on the side)• Is also intended for expanding the system bus or increasing the system bus range via RJ45 sockets on the front (1 x Bus In, 2 × Bus Out)
Router module 1-port (as of system version 4)	705043	<ul style="list-style-type: none">• Use together with a JUMO variTRON 300 or JUMO variTRON 500 touch central processing unit for connecting the modules (system bus input via RJ45 socket; system bus output on the side)• Is also intended for system bus expansion

Special modules - 7051xx JUMO I/O system

Module designation	Data sheet	Features
Communication module 2-channel	705162	<ul style="list-style-type: none">• Use together with a system module on a JUMO variTRON 300, JUMO variTRON 500, or JUMO variTRON 500 touch central processing unit• External voltage supply DC 24 V SELV und EtherCAT In via side plug connector• Side socket for voltage supply^a and EtherCAT Out• Interface 2 x RJ45 EtherCAT Out• Alias device address can be set via DIP switch

1 Introduction

Module designation	Data sheet	Features
Communication module 3-channel	705163	<ul style="list-style-type: none"> • Use together with a system module on a JUMO variTRON 300, JUMO variTRON 500, or JUMO variTRON 500 touch central processing unit • External voltage supply DC 24 V SELV und EtherCAT In via side plug connector • Side socket for voltage supply^a and EtherCAT Out • Interface 1 x RJ45 EtherCAT In • Interface 2 x RJ45 EtherCAT Out • Alias device address can be set via DIP switch
System module	705171	<ul style="list-style-type: none"> • Connection of the I/O modules or communication modules 7051xx (voltage supply and system bus) to a central processing unit JUMO variTRON 500^b • External voltage supply DC 24 V SELV und EtherCAT In

^a The 3-port module takes over the voltage supply at the start of a strand. In order to break the 8 A limit, a 2-port router can be used for supply again.

^b With the system module, mixed operation of JUMO variTRON modules (7050xx) and I/O modules (7051xx) is possible by placing the system module on the last 7050xx module and then adding on the 7051xx modules. The setup program displays where which modules can be arranged in the HW wizard. Mixed operation can also be carried out via the relevant router modules.

Panels

Module designation	Data sheet	Features
JUMO variTRON web panels	705070	<ul style="list-style-type: none"> • Versions for different requirements (e.g. Standard, Food & Beverage) • Screen sizes (diagonal) from 10.9 cm (4.3") to 54.6 cm (21.5") • TFT-touchscreen, capacitive or resistive

Power supply units

Module designation	Data sheet	Features
Power supply unit 705090/03-33	705090	<ul style="list-style-type: none"> • AC 100 to 240 V wide-range input • Output: DC 24 V / 3.4 A
Power supply unit 705090/05-33	705090	<ul style="list-style-type: none"> • AC 100 to 240 V wide-range input • Output: DC 24 V / 5 A
Power supply unit 705090/10-33	705090	<ul style="list-style-type: none"> • AC 100 to 240 V wide-range input • Output: DC 24 V / 10 A

1.8 Available technical documentation

The documentation for the automation system is addressed to plant manufacturers and users with specialist training and consists of the following documents (previous document number in brackets).

1.8.1 Central processing unit

Product	Document	No.	Printed	PDF file
variTRON 300	Data sheet	70500300T10...	-	X
Central processing unit	Operating manual	70500300T90...	-	X
	Installation Instructions	70500300T94...	X	X
	Security Manual	70500000T95...	-	X

1.8.2 Input/output modules

7050xx JUMO variTRON

Product	Document	No.	Printed	PDF file
Multichannel controller module	Data sheet	70501000T10...	-	X
	Operating manual	70501000T90... (B 705010.0)	-	X
	Installation instructions	70501000T94... (B 705010.4)	X	X
Relay module 4-channel	Data sheet	70501500T10...	-	X
	Operating manual	70501500T90... (B 705015.0)	-	X
	Installation instructions	70501500T94... (B 705015.4)	X	X
Analog input module 4-channel	Data sheet	70502000T10...	-	X
	Operating manual	70502000T90... (B 705020.0)	-	X
	Installation instructions	70502000T94... (B 705020.4)	X	X
Analog input module 8-channel	Data sheet	70502100T10...	-	X
	Operating manual	70502100T90... (B 705021.0)	-	X
	Installation instructions	70502100T94... (B 705021.4)	X	X
Analog output module 4-channel	Data sheet	70502500T10...	-	X
	Operating manual	70502500T90...	-	X
	Installation instructions	70502500T94...	X	X
Digital input and output module 12-channel	Data sheet	70503000T10...	-	X
	Operating manual	70503000T90... (B 705030.0)	-	X
	Installation instructions	70503000T94... (B 705030.4)	X	X
Digital input and output module 32-channel (as of system version 3)	Data sheet	70503100T10...	-	X
	Installation instructions	70503100T94...	X	X

1 Introduction

Thyristor power controller type 70906x (as of system version 3)	Operating manual (integration into the automation system)	70500153T90...	-	X
---	---	----------------	---	---

7051xx JUMO I/O system

Product	Document	No.	Printed	PDF file
Multichannel controller module	Data sheet	70515200T10...	-	X
	Operating manual	70515200T90...	-	X
Analog input module 4-channel	Data sheet	70511300T10...	-	X
	Operating manual	70511300T90...	-	X
Analog output module 4-channel	Data sheet	70512300T10...	-	X
	Operating manual	70512300T90...	-	X
Digital input module 16-channel	Data sheet	70513500T10...	-	X
	Operating manual	70513500T90...	-	X
	Installation instructions	70513500T94...	X	X
Digital output module 4-channel	Data sheet	70514300T10...	-	X
	Operating manual	70514300T90...	-	X
	Installation instructions	70514300T94...	X	X
Digital output module 16-channel	Data sheet	70514500T10...	-	X
	Operating manual	70514500T90...	-	X
	Installation instructions	70514500T94...	X	X

1.8.3 Special modules

7050xx JUMO variTRON

Product	Document	No.	Printed	PDF file
Router module 2-port (as of system version 3)	Data sheet	70504100T10...	-	X
	Installation instructions	70504100T94...	X	X
Router module 3-port (as of system version 3)	Data sheet	70504200T10...	-	X
	Installation instructions	70504200T94...	X	X
Router module 1-port (as of system version 4)	Data sheet	70504300T10...	-	X
	Installation instructions	70504300T94...	X	X

7051xx JUMO I/O system

Product	Document	No.	Printed	PDF file
Communication module 2-channel	Data sheet	70516200T10...	-	X
	Operating manual	70516200T90...	-	X
	Installation instructions	70516200T94...	X	X
Communication module 3-channel	Data sheet	70516300T10...	-	X
	Operating manual	70516300T90...	-	X
	Installation instructions	70516300T94...	X	X
System module	Data sheet	70517100T10...	-	X
	Operating manual	70517100T90...	-	X
	Installation instructions	70517100T94...	X	X

1.8.4 Panels

Product	Document	No.	Printed	PDF file
JUMO variTRON Web panels	Data sheet	70507000T10...	-	X

1.8.5 Power supply units

Product	Document	No.	Printed	PDF file
24 V power supply units	Data sheet	70509000T10...	-	X
	Operating instructions QS3.241		X	-
	Operating instructions QS5.241		X	-
	Operating instructions QS10.241		X	-

1 Introduction

1.9 System version

The system version of the automation system is determined by the software version of the central processing unit.

Example composition of a version number for the central processing unit: 431.x.y.z.b

431 = basic number

x = major version (= system version)

y = minor version

z = patch version

b = build number

In this document, functions which depend on the system version are marked accordingly (e.g. "as of system version x").

1.10 Declaration of conformity



NOTE!

Hereby JUMO GmbH & Co. KG declares that the radio equipment type JUMO variTRON 300 is in compliance with Directive 2014/53/EU. The full text of the EU declaration of conformity is available at the following Internet address: qr-705003-en.jumo.info



JUMO variTRON 300

The central processing unit JUMO variTRON 300 is based on a new hardware platform with a 792 MHz processor (single core).

Due to the scalability of hardware and software, a modular, flexible, and above all sustainable hardware platform is available that is combined with a modern software architecture. Based on this new platform, innovative operating concepts can now be implemented using state-of-the-art display technologies.

The advantages at a glance:

- High speed performance
- Flexible operating philosophy
- Modern communication interfaces (e.g. OPC UA, MQTT)
- Integration of different fieldbus protocols such as PROFINET IO, EtherCAT, Modbus TCP/RTU, and BACnet/IP
- Easy integration of new software functions via PLC (CODESYS V3.5)
- Availability of function and visualization libraries (as of system version 6)
- Easy adaptation of hardware inputs and outputs
- Connection of the JUMO Wtrans transmitters (as of system version 5)
- Customized operation and visualization with several operator stations via CODESYS remote target visualization or web panels via web visualization (mixed operation is possible)
- Panels in various formats (portrait or landscape, 4:3 or 16:9)
- Web Cockpit

The central processing unit is connected to the router module using a standard network cable (see technical data or accessories). The voltage for the router module as well as the connected input and output modules is supplied at the router module. That way, the central processing unit and router module can also be mounted on different DIN rails (cable length max. 100 m).

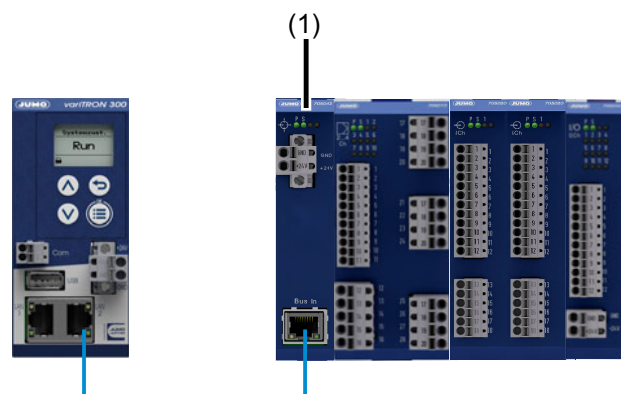

- 1 Router module 1-port (705043), connected to JUMO variTRON 300 central processing unit (705003)

2 Description

Input/output modules

The proven input and output modules are available as module variants (type 7050xx; incl. controller module).

Up to 8 input and output modules can be connected to the JUMO variTRON (7050xx series). Up to 8 input and output modules can be connected to the JUMO I/O system (7051xx series).¹

For example: the analog input module with universal inputs for thermocouples, RTD temperature probes, and voltage or current standard signals. As a result the same hardware can be used to precisely acquire and digitize a highly diverse range of process variables.

JUMO variTRON 300 enables simultaneous operation of numerous control loops so that it can also be used for sophisticated processes. The control loops here operate fully independently, which means they do not require resources from the central processing unit.

Thyristor power controllers can also be connected via EtherCAT or PROFINET. In addition, JUMO dig-iLine sensors for liquid analysis can be connected to the central processing unit.

Wireless measured value transmission

As from system version 5, the JUMO variTRON 300 central processing unit is also available with a wireless interface that enables wireless transmission of measured values. The transmitters of the JUMO Wtrans series are available as measuring probes (Wtrans T, Wtrans B, Wtrans p; Wtrans E01 as of system version 6). A maximum of 32 transmitters can be operated on the central processing unit.

During startup, the display of the RSSI value (Received Signal Strength Indicator) in the Web Cockpit is helpful as an indicator of the signal strength of a received radio telegram.

¹ The number of modules depends on the cycle time configured for the system bus master, the active process values, the type of connection modules and the system load. Router modules are not taken into account when calculating the maximum admissible number of modules.

2.1 Identifying the device version

2.1.1 Nameplate

Position

The nameplate (A) is affixed to the module case.

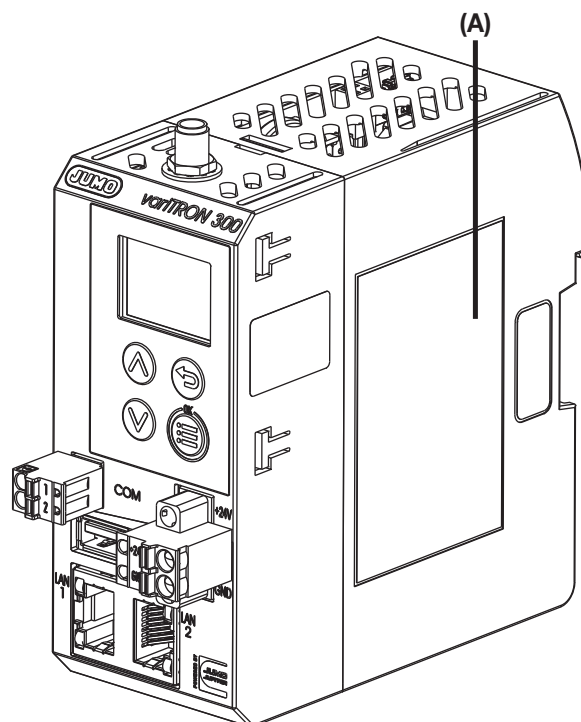

Table of contents

The nameplate contains important information. This includes:

Description	Designation on the nameplate	Example
Device type	Type	705003/01008-00-36/000.224
Part no.	TN	00123456
Fabrication number	F-Nr.	0070033801220500006
Voltage supply	-	DC 24 V, +25/-20 %

Device type (Typ)

Compare the specifications on the nameplate with the order.

Identify the supplied device version using the order details (order code).

Part no. (TN)

The part no. uniquely identifies an article in the catalog. It is important for communication between the customer and the sales department.

Fabrication number (F-Nr.)

The fabrication number indicates, among other things, the date of manufacture (year/week).

Example: F-Nr = 00700338012**20**500006

The characters in question are digits 12, 13, 14, and 15 (from the left).

The device was therefore produced in the 50th week of 2020.

2 Description

2.1.2 Order details

(1) Basic type	
705003	Central processing unit type 705003 (2 × Ethernet (RJ45), 1 × USB host, 1 × RS485), program generator, Node-RED, math and logic module ^a , ST code for controller module ^b , communication protocols (PROFINET IO-Controller, Modbus RTU / TCP Master/Slave, OPC UA Server ^c , EtherCAT Master, BACnet/IP)
(2) Basic type extension 1	
0	Single core CPU
(3) Basic type extension 2	
1	RAM 512 MB
(4) Basic type extension 3	
1	eMMC 2 GB ^d
(5) Version	
8	Standard with default settings
(6) Wireless interface	
00	Without interface
10	Wtrans 868.4 MHz (Europe)
20	Wtrans 915 MHz (USA, Australia, Canada, New Zealand, etc.)
(7) Voltage supply	
36	DC 24 V +25/-20 %, SELV
(8) Extra codes^e	
062	DNV® approval ^f
224	PLC according to IEC 61131-3 (CODESYS V3.5; necessary to operate the device as a PLC) ^g
280	CODESYS Remote TargetVisu ^{g, h}
281	CODESYS WebVisu ^g

^a Activation for all connected controller modules (705010).

^b Available for all controller modules of the type 705152.

^c OPC UA Server: Available as of system version 7.

^d Flexible allocation between system data and application data.

^e The central processing unit can be extended with various functions through extra codes. For performance reasons, it may not be possible to use all functions (extra codes) at the same time, depending on the specific application. The JUMO variTRON 500 central processing unit (type 705002) is available as a higher-performance device. Your contact person in Technical Sales will be happy to advise you on selecting the appropriate central processing unit for your application.

^f Not in combination with wireless interface. The power supply unit used must also have a DNV® approval (e.g. type 705090).

^g This function can be used free of charge for 30 minutes in demo mode.

^h Only in conjunction with extra code 224.

Order code (1) (2) (3) (4) (5) (6) (7) (8)
 705003 / 0 1 1 - 8 - - 36 / 224 , ...^a

Order example 705003 / 0 1 1 - 8 - 00 - 36 / 224

^a List further extra codes in sequence, separated by commas.

2.1.3 Scope of delivery

1 central processing unit, type 705003, in the ordered version
1 lambda/4-antenna (only for device with wireless interface)
1 installation instructions

2 Description

2.1.4 Accessories

Designation	Part no.
Extra codes (activations):	
PLC according to IEC 61131-3 (CODESYS V3.5; necessary to operate the device as a PLC)	00724988
Remote TargetVisu	00724990
CODESYS WebVisu	00724991
USB to Ethernet converter ^a :	
TP-Link UE300 USB to Gigabit LAN Converter ^b (as of system version 8)	30047695
Network cable ^a :	
RJ45 patch cable SF/UTP, length 0.3 m	00747472
RJ45 patch cable S/FTP, Cat. 6A, length 1.5 m	00666324
RJ45 patch cable S/FTP, Cat. 6A, length 3 m	00666326
RJ45 patch cable S/FTP, Cat. 6A, length 5 m	00665966
RJ45 patch cable S/FTP, Cat. 6A, length 10 m	00666327
Accessories for wireless interface ^a :	
Antenna cable, length 1 m, impedance 50 ohm with preconfigured screw-type connection, T _{max.} 85 °C	00710813
Antenna cable, length 3 m, impedance 50 ohm with preconfigured screw-type connection, T _{max.} 85 °C	00482646
Antenna cable, length 5 m, impedance 50 ohm with preconfigured screw-type connection, T _{max.} 85 °C	00490066
Antenna cable, length 5 m, impedance 50 ohm with preconfigured screw-type connection, T _{max.} 125 °C	00660378
Antenna cable, length 10 m, impedance 50 ohm with preconfigured screw-type connection, T _{max.} 85 °C	00490068
Antenna cable, length 10 m, impedance 50 ohm with preconfigured screw-type connection, T _{max.} 125 °C	00511870
Antenna holder for wall mounting with antipole for lambda/4 antenna	00482648
Lambda/4 antenna with waterproof, permanently connected cable, length 10 m, T _{max.} 125 °C	00757047
Lambda/4-antenna, impedance 50 ohm, T _{max.} 125 °C	00757039
Amplifier ZX60-0916LN, packaged (ambient temperature -25 to +125 °C)	00715285
Starter kits ^c :	
variTRON 300 starter kit	

^a The accessories are not part of the device approvals.

^b This USB to Ethernet converter with RTL8153 chipset has been tested by the manufacturer. Other USB to Ethernet converters with the same chipset should also be usable, as well as converters with the following chipsets: Realtek RTL8150, RTL8152, RTL8153ASIX AX88xxx based, AX88179, AX-88178ASMSC LAN95XX based.

^c Ordering is only possible via the contact person at the manufacturer.

2.2 Device functions

Recorder – recording of process data

As of system version 6, the JUMO variTRON 300 central processing unit has a function for acquiring process data as a standard feature. This allows up to 60 analog or digital channels (signals) to be logged. The channels are combined into groups for this purpose.

By grouping the channels, the user can, for example, create a separate group for each plant or log signals with a different memory cycle. The grouping of channels is also the basis for acquiring batches.

The process data is stored in the central processing unit before this data is transferred to the Datastore for storage. The Datastore is part of the JUMO smartWARE Evaluation software, which is used to visualize and evaluate the data. A fee-based license is required for this purpose. Visualization using only the central processing unit is not possible.

Acquisition of batches

As of system version 6, the scope of the JUMO variTRON 300 central processing unit also includes the acquisition of batches. Up to 10 batches can therefore be logged at the same time.

The batch data is acquired together with the channels (signals) of the assigned groups and the event messages.

The batches are also only temporarily stored in the central processing unit. Storage, visualization, and evaluation are then carried out with the JUMO smartWARE Evaluation software. A fee-based license is also required for this purpose (number of batches).

2 Description

2.3 Software

JUMO Cloud

The IoT platform for process visualization as well as data acquisition, evaluation, and archiving enables worldwide access to measurement data using common web browsers. The JUMO Cloud is characterized by a high degree of security as well as valuable visualization, alarm, and planning functions.

Further information on the JUMO Cloud:

qr-en-cloud.jumo.info

JUMO smartWARE SCADA

The JUMO smartWARE SCADA software provides easy access to measurement data using conventional web browsers. It offers functions for process visualization as well as for evaluation of the acquired data. The software also supports manufacturing and work processes with valuable visualization, alarm, and planning functions.

Further information on the JUMO smartWARE SCADA software:

qr-en-scada.jumo.info

JUMO smartWARE Evaluation

JUMO smartWARE Evaluation is intended for evaluating and visualizing process data from the JUMO variTRON system. The process data can be evaluated in customizable dashboards based on time or batch and transferred into reports (e.g. PDF, Excel®, CSV).

Further information on the JUMO smartWARE Evaluation software:

qr-en-evaluation.jumo.info

3.1 General information on installation/dismounting



DANGER!

With multichannel controller module 705010, 705152 and relay module 705015, 705143, the load circuits from relay or solid state relay outputs can be operated with a dangerous electrical voltage (e.g. 230 V).

There is a risk of electric shock.

- ▶ Prior to the installation/dismounting of these modules or the removal of the module insert, the load circuits are to be disconnected from the voltage and the terminal strips are to be removed from the module. This work must only be performed by qualified personnel.



WARNING!

The modules must never be installed in areas with an explosion hazard.

Explosion hazard.

- ▶ The entire system must only be used outside of areas with an explosion hazard.

Mounting site

All modules have protection type IP20 and are only intended for use in fireproof control cabinets or switch boxes. The mounting site should be virtually vibration-free. Electromagnetic fields caused by equipment such as motors or transformers should be avoided.

Type 705070 panels are designed for installation in a panel cut-out. Information on the protection type and other technical data can be found in data sheet 705070.

Climatic conditions

The ambient temperature and the relative humidity at the mounting site must correspond to the technical data. Aggressive gases and vapors have a negative effect on the operating life of the modules. The mounting site must be free from dust, powder, and other suspended matter so that the cooling slots do not become blocked.

DIN rail

All modules are mounted on a DIN rail according to DIN EN 60715 (35 mm × 7.5 mm × 1 mm). For reasons of stability, the spacing of the fastening screws for the DIN rail should not exceed 200 mm. The minimum distances for the modules that are specified in the module-specific installation or operating instructions must be observed.

Installation position

The DIN rail should be mounted horizontally so that all modules are arranged vertically. Otherwise the admissible ambient temperature range will be restricted.

Space requirement

The modules require the minimum distances shown in the following figure for the purpose of installation/dismounting and for future maintenance or replacement. In the event of shorter distances the minimum bending radius of the cables, the performance of the electrical installation, and the clear arrangement of the plant are no longer guaranteed.

Cleaning

Only use a dry cloth for cleaning the modules (protection type IP20).

3 Mounting

Minimum distances

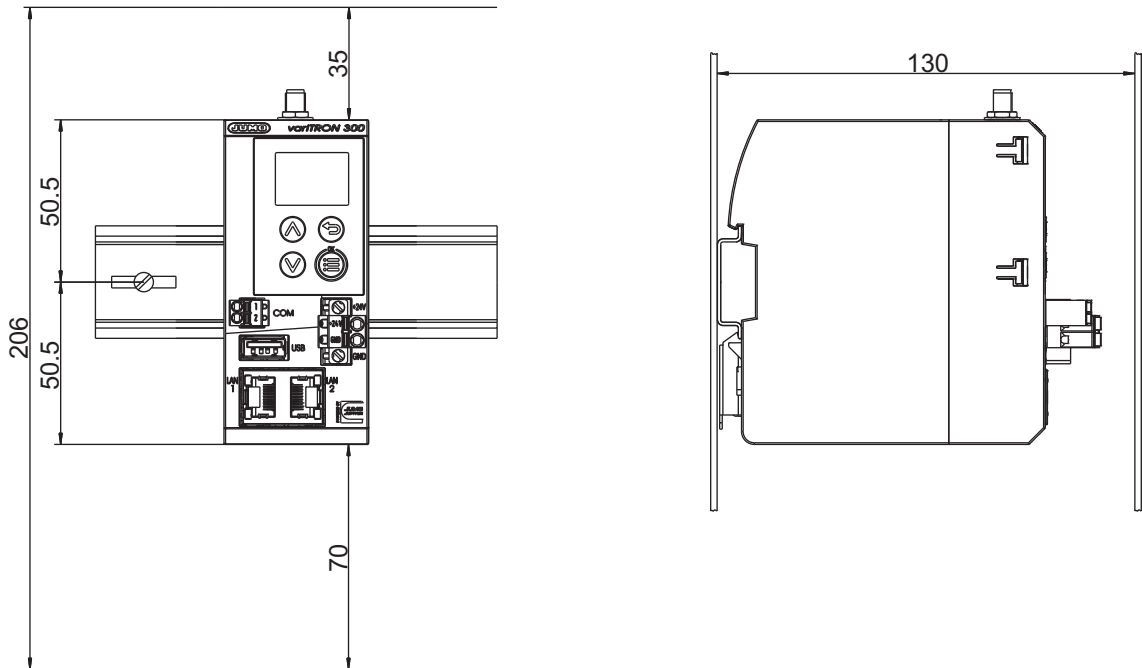

NOTE!

The upper minimum distance 35 mm is sufficient to connect a cable to the antenna socket. If the antenna is connected directly to the antenna socket, a minimum distance of 100 mm is required.

3.2 Installation/dismounting on DIN rail

All modules in the system are intended for installation on a DIN rail according to DIN EN 60715 (35 mm × 7.5 mm × 1 mm).

The following must always be installed on the left side at the start of the DIN rail:

- A central processing unit *or*
- A router module 705042 (or 705043) *or*
- A 3-channel communication module 705163

These connect the input or output modules to the voltage supply and the system bus.



NOTE!

To determine the required minimum width of the DIN rail, the widths of the individual modules must be added (see technical data of the modules in the respective data sheet or the module-specific installation instructions).

The widths of the cover (17.5 mm) and both end brackets (9.5 mm each) should also be taken into consideration: $17.5 \text{ mm} + 2 \times 9.5 \text{ mm} = 36.5 \text{ mm}$.

3.2.1 Central processing unit

Installation of the central processing unit

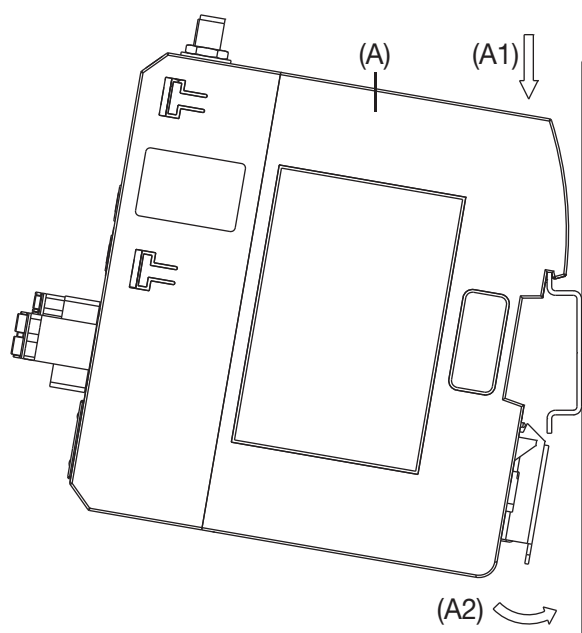

Process:

1. Mount the central processing unit (A) on the DIN rail from above (A1).
2. Pivot the central processing unit (A) downwards until it snaps into place (A2).



NOTE!

If necessary, activate the terminating resistors of the RS485 interface before installation (see chapter "Electrical connection")!

3 Mounting

Dismounting of the central processing unit

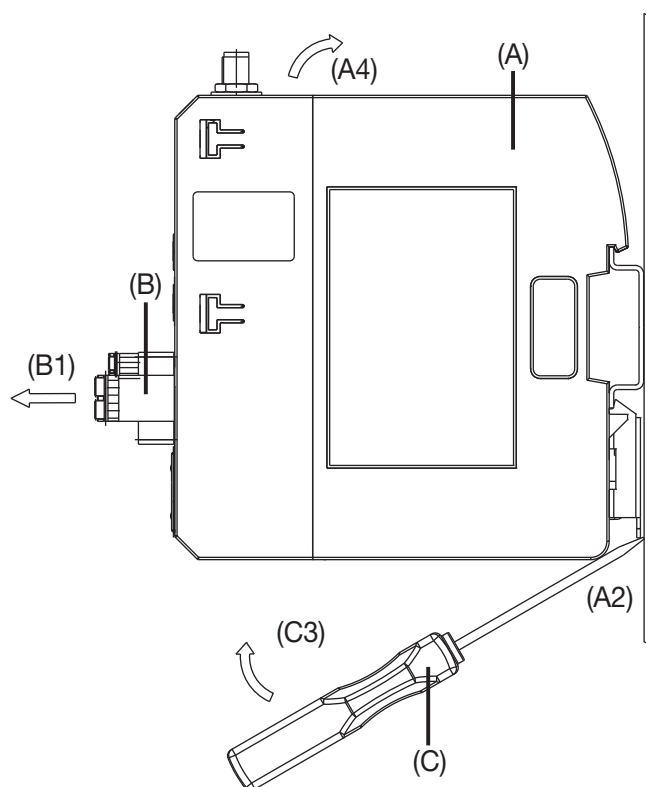

Process:

1. Remove the connecting cables if required (interfaces).
2. If required, use a screwdriver to release the wired terminal (B) of the central processing unit (A) and pull off toward the front (B1).
3. Insert a suitable screwdriver (C) into the unlocking slot of the central processing unit (A2) and press upward (C3).
4. Pivot the central processing unit (A) upward off the DIN rail (A4) and remove it.

3.3 Dimensions

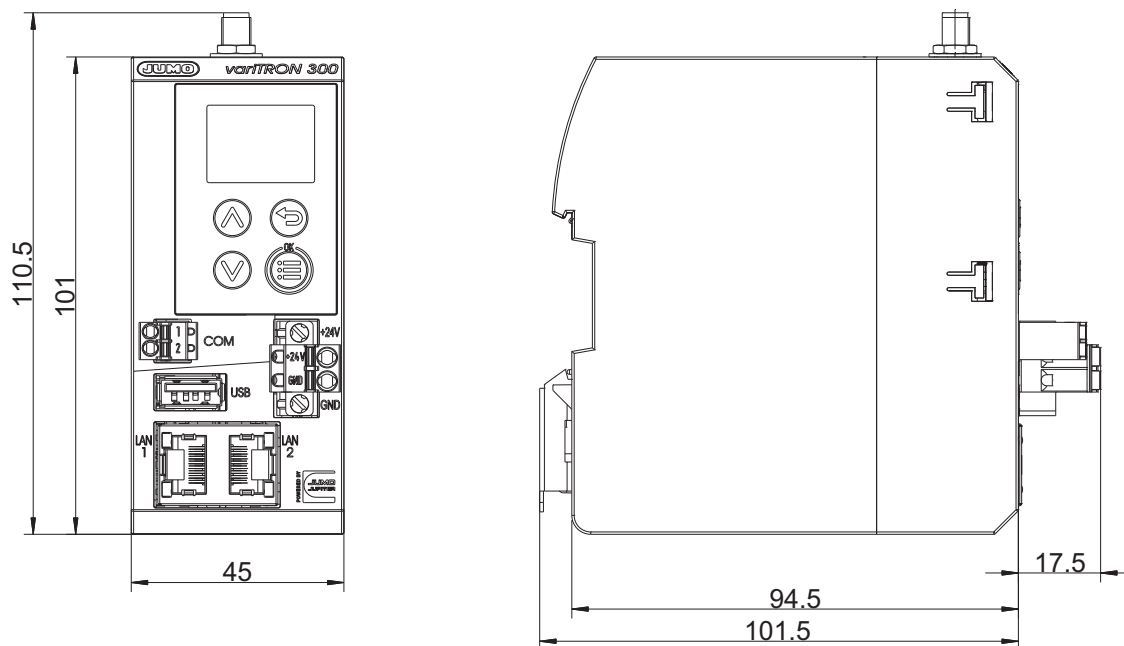

4 Electrical connection

4.1 Installation notes



NOTE!

These installation notes apply for the entire automation system and, on some occasions, are only applicable for a specific module. The respective connection diagram shows the context.

Requirements for personnel

- Work on the modules must only be carried out to the extent described and, like the electrical connection, only by qualified personnel.
- Before plugging and unplugging connecting cables, it must be ensured that the acting person is electrostatically discharged (e.g. by touching grounded metallic parts).

Cables, shielding, and grounding

- When selecting the cable material, when installing, and when performing the electrical connection of the module, the regulations of DIN VDE 0100 "Erection of low voltage installations" or the respective national regulations (e.g. on the basis of IEC 60364) are to be observed.
- At maximum load, certain cables must be heat resistant up to at least 80 °C. The corresponding notes in the connection diagram of the affected modules must be observed.
- Route input, output, and supply lines separately and not parallel to one another.
- Only use shielded and twisted probe and interface cables. Do not route the lines close to current-carrying components or cables.
- For temperature probes, ground the shielding on one side in the control cabinet.
- Do not perform loophroughs on the grounding cables, but instead route the cables individually to a shared grounding point in the control cabinet. In doing so, ensure that the cables are as short as possible.

Ensure that the potential equalization is correct.

Electrical safety

- Isolate power supply units from the voltage supply on the primary side if there is a risk of touching parts with dangerous electrical voltage (e.g. 230 V) during active use.
- The fuse rating of the power supply units on the primary side should not exceed a value of 10 A (inert).
- With modules that have relay or solid state relay outputs, the load circuits can be operated with a dangerous electrical voltage (e.g. 230 V). Disconnect load circuits from the voltage supply during installation/dismounting and electrical connection.
- In order to prevent the destruction of the relay or solid state relay outputs in the event of an external short circuit in the load circuit, the load circuit should be fuse-protected to the maximum admissible output current.
- The modules are not suitable for installation in potentially explosive areas.
- In addition to a faulty installation, incorrectly set values on the module could also impair the correct function of the following process. Therefore, ensure that safety devices independent of the module (e.g. overpressure valves or temperature limiters/monitors) are available and that it is only possible for qualified personnel to define settings. Please observe the corresponding safety regulations in this context.

References to other information

- The electromagnetic compatibility meets the standards and regulations cited in the technical data.
- Sometimes USB interface and power supply are not electrically isolated. In general, please observe the device-specific information on galvanic isolation.

4.2 Electrical isolation

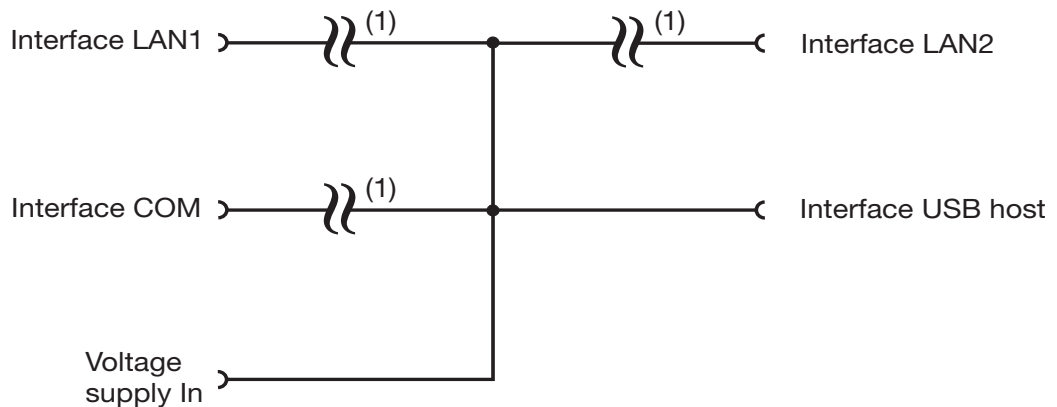

1 Functional galvanic isolation for connection of SELV or PELV electrical circuits.

4.3 Connection diagram



CAUTION!

At maximum load, the temperature may exceed 60 °C at the terminals "+24 V" and "GND" (voltage supply In).

As a result the insulation of the cable may be damaged.

- ▶ The cable must be heat resistant up to at least 80 °C.



NOTE!

Only copper conductors are allowed to be connected to the terminals.



NOTE!

Use within the scope of DNV approval:

The module must be supplied by a power supply unit that also has DNV approval. Further modules of the automation system may be operated at this power supply unit. Other devices must not be connected to this power supply.

4 Electrical connection

4.3.1 Display, operating, and connection elements

This overview shows the position of the display, operating, and connection elements. The assignment to individual functions is illustrated in the following sections.

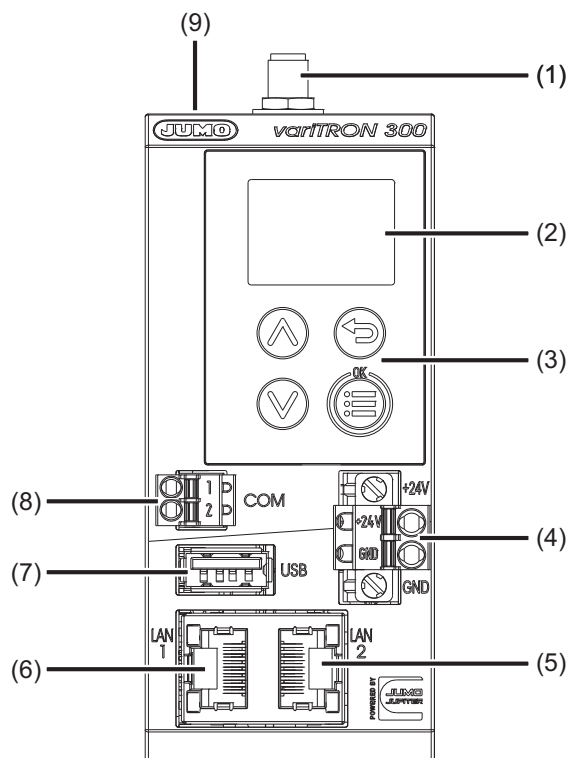

- (1) Antenna connector
- (2) Display
- (3) Control elements
- (4) Voltage supply DC 24 V
- (5) Interface LAN2
- (6) Interface LAN1
- (7) USB host interface
- (8) RS485 interface
- (9) Switches for terminating resistors (RS485), inside the housing

4 Electrical connection

4.3.2 Voltage supply

Connection	Designation	Number	Symbol and terminal designation
Voltage supply In	+24 V and GND	(4)	

4.3.3 Interfaces

Connection	Designation	Number	Connection element	Assignment
Antenna (optional)		(1)	SMA socket	
Ethernet	LAN1, LAN2	(6), (5)		1 TX+ Transmission data + 2 TX- Transmission data - 3 RX+ Received data + 6 RX- Received data -
USB host	USB	(7)	USB socket type A	
Serial interface RS485	COM	(8)	Terminal strip 2-pole	1 TxD+/RxD+ Transmission/received data + 2 TxD-/RxD- Transmission/received data -



NOTE!

Only SELV or PELV circuits may be connected to the interfaces.

The connection cables of the Ethernet interfaces may only run inside the building.

4 Electrical connection

4.3.4 Terminating resistors

The terminating resistors of the RS485 interface are deactivated per default. To activate them, switches 1 and 2 must be closed.

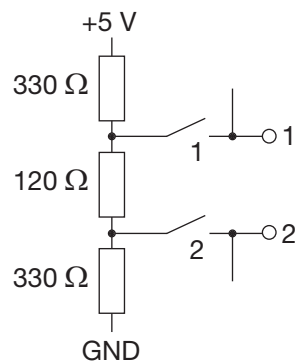

The switches are located inside the housing and are accessible through the ventilation slots (1).

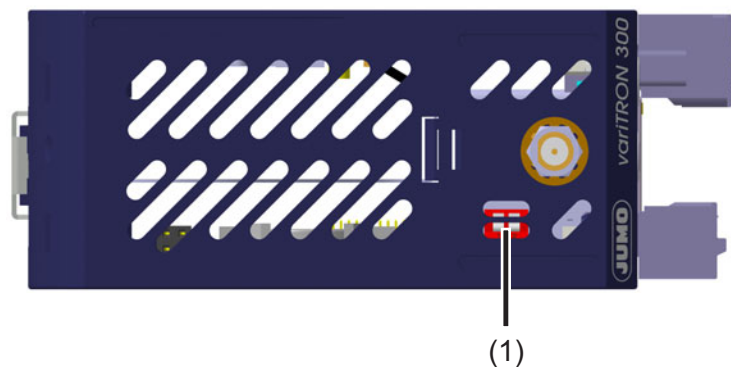

Switch position: up = open, down = closed



NOTE!

To ensure fault-free operation, terminating resistors are required at the beginning and end of an RS485 transmission path.

5.1 General information

The following options are available to operate the device:

- Configuration of the device with the setup program (basic software and variTRON plugin)
- Operation on the device
- Use of the JUMO Web Cockpit with the "Web Cockpit", the "Recorder View" (only with JUMO variTRON 500 und JUMO variTRON 500 touch), "CODESYS WebVisu" and "Other apps" in a web browser. The "Other apps" tile takes you directly to the JUMO Help Center.
- Use of the "JUMO smartWARE Evaluation" web application using a web browser

The various options for operating the device differ in terms of the scope of the functions they support.

IP address

In order to access the device using the setup program or a web browser, the IP address of the device is required. The IP address of the Ethernet interface concerned can be found using the **device menu**:

Applications > Main menu > Device info > Ethernet > LANx

A user does not need to be logged on to do this (dependent on rights).

The Ethernet settings may need to be changed beforehand using the device menu:

Applications > Main menu > Configuration > Ethernet > LANx

Network

- Method: Automatic
- Check Obtain DNS server IP automatically

A user does not need to be logged on to do this (as of system version 8; dependent on rights).

The default setting is that DHCP is active.

User log-on

Please use the following details to logon for startup purposes:

- Username: Master
- Password: 9200

The password should be changed after completing the startup at the latest.

The password must be entered again each time the user logs on.

Hardware configuration

In order to start up a system that comprises the device (central processing unit) and other system components (modules), the system's hardware configuration needs to be created using the **setup program**. This cannot be done using the device menu or the web application.

If the hardware is incorrectly configured, a bus error will be displayed.

Startup

Procedure during startup:

⇒ chapter 7 "Startup", Page 116

Device-specific information in this chapter

All information in this chapter fundamentally applies to the devices JUMO variTRON 300 (705003), JUMO variTRON 500 (705002), and JUMO variTRON 500 touch (705004). Differences between the devices will be mentioned at the relevant points if necessary for the use of this manual. Device-specific sections or subchapters are also used where required.

5 Operation

5.2 Device



CAUTION!

Danger due to electrostatic discharge!

Touching the connection elements can destroy the device.

- ▶ The operator must discharge himself electrostatically before operating the device.

5.2.1 Display and control elements

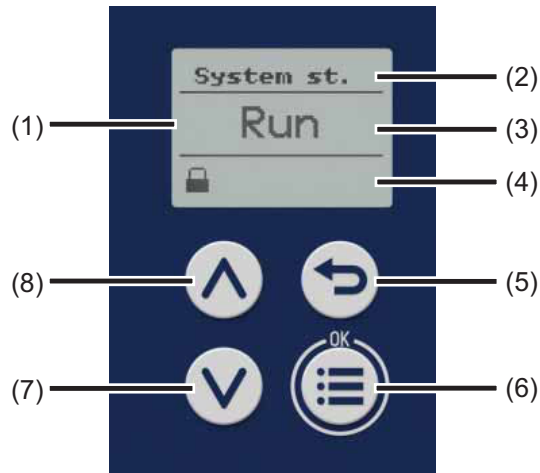

- 1 Display in basic status
- 2 Title of display
- 3 Display of system status or system bus status
- 4 Display of log-on status or event, e.g. using icons (see table)
- 5 "Back" key (in menu: back to previous menu level, exit editing mode without making a change)
- 6 "Menu/OK" key (call up main menu, switch to submenu/level, switch to editing mode, exit editing mode with a change made, confirm entry or change)
- 7 "Down" key (in menu: reduce value, select next menu item, parameter, or value; in basic status: switch between displaying the system status and the system bus status)
- 8 "Up" key (in menu: increase value, select previous menu item, parameter, or value; in basic status: switch between displaying the system status and the system bus status)

Icons (display in basic status)

Icon designation	Depicted as	Meaning
Logon status (position 1 = left)		User is not logged on.
		User is logged on.
Alarm status (position 2)		There is at least one malfunction (but no alarm).
		There is at least one alarm.
External medium (position 3)		An external medium has been connected (USB port).
Transfer of configuration (position 4)		Configuration is being transferred (setup program).

Icon designation	Depicted as	Meaning
CODESYS online status (position 5)		The CODESYS programming system has been connected to the device.

5.2.2 Device menu

To access the device menu from the start screen, press the "Menu/OK" key.

The following overview shows the menu levels where individual functions can be configured (by selecting or entering data) or information is shown. The information that is shown on the device display depends on the user's rights.

Beyond this, there are functions that can only be configured with the setup program or the web application; these functions are not listed here.

If you need further information on the individual functions, please see the subsequent chapters in this manual (see cross-references).

User management

Sub-menu 1	Sub-menu 2	Sub-menu 3
Logon (log in)	User (to be selected), password (to be entered)	---
Logoff (log out)	---	---

⇒ chapter 5.2.3 "User log-on", Page 43

System status

Sub-menu 1	Sub-menu 2	Sub-menu 3
Change the system status Selection options: Run, Stop, Reset, Reset (Cold), Reset (Origin), Reboot system	---	---

⇒ chapter "Device information", Page 71

Configuration

Sub-menu 1	Sub-menu 2	Sub-menu 3
Device manager	Device settings	Device language (selection)
		Start-up behavior (selection options: Run, Stop, Last status)
		Partition change after [x] start-up errors (to be entered)
	Device designations	Device name (display)
		DNS name (display)
	Time zone/NTP	Time zone (selection)
		NTP active (selection)
Max. round-trip time (to be entered)		

5 Operation

Sub-menu 1	Sub-menu 2	Sub-menu 3
Ethernet	LAN1	Method (selection options: Manual, Automatic)
		IP address (to be entered)
		Subnet mask (to be entered)
		Standard gateway (to be entered)
		DNS server IP (obtain automatically; selection options: False, True)
	DNS server (entry of IP address)	
	LANx	see LAN1
Web server	HTTP (selection options: Active, Inactive, Redirect to HTTPS)	---
	HTTP port number (to be entered)	---
	HTTPS port number (to be entered)	---
System status UI	Screensaver	Function (selection options: Off, On)
		Waiting period (idle time) (to be entered, in milliseconds)

⇒ chapter "Configuration", Page 75

Device info

Sub-menu 1	Sub-menu 2	Sub-menu 3
Device information	Device	Device name (display)
		Date and time (display)
		Total root volume memory (display)
		Product group (display)
		Recorder service ID (display)
		Certification number (inspection number) (display)
		Fabrication number (production number) (display)
	Hardware versions	(dependent on what hardware is fitted to the device) Submenu 4 displays: – Hardware type – Comment – LP ID – Compatibility index – Hardware version
		Software versions
	Version type (display)	
	Operating system version (display)	
	Application building version (display)	
	Software version (display)	
System status	System status (display)	---
Ethernet	LAN1	IP address (display)
		Transfer rate (display)
		MAC address (display)
		DNS server (display)
		Standard gateway (display)
		Subnet mask (display)
	LANx	see LAN1

⇒ chapter "Device information", Page 71

Service

Sub-menu 1	Sub-menu 2	Sub-menu 3
Device manager	Activate debug interface (selection) As of system version 6: An automatically generated SSH password is stored in the event list (valid until power off).	---
Certificate administration	Remove certificates (selection)	---
Email	Send email (selection)	---

5 Operation



CAUTION!

The SSH password gives the user unrestricted access to the operating system (root privileges).

Changes at the operating system level can result in the device functions developed and tested by JUMO being inadmissibly changed. JUMO accepts no liability for this.

- ▶ The user is responsible for all changes he makes at the operating system level.
-

Removable media

This menu item is provided if a USB flash drive has been connected.

Sub-menu 1	Sub-menu 2	Sub-menu 3
Remove hardware Must be run before the USB flash drive is removed!	---	---
Import configuration	---	---
Export configuration	---	---
Firmware update	---	---
Export debug data	---	---
Export license query (as of system version 4)	Functions (extra codes) that can be enabled. A separate request file (license request) must be exported for each function.	---
Import license file (as of system version 4)	If several functions are available, they must be enabled one after the other. A separate response file (license file) is required for each function.	---
Export recording data (as of system version 10)	---	---

5.2.3 User log-on

Logon

- 1) Press the "Menu/OK" key to open the device menu.
- 2) Switch to the submenu "User administration > Logon".
- 3) Select the user from the list and press the "Menu/OK" key to confirm.
- 4) Enter the password: Select the 1st digit by pressing the "Up" or "Down" key and press the "Menu/OK" key to confirm.
- 5) Enter the subsequent digits of the password one after the other.
- 6) Once you have entered the last digit, press the "Menu/OK" key again.

Logoff

- 1) Press the "Menu/OK" key to open the device menu.
- 2) Switch to the submenu "User administration > Logoff".
- 3) Press the "Menu/OK" key.

5.2.4 Reset to factory settings

To perform a reset to default settings, first switch off the device (device disconnected from the voltage supply), then simultaneously press the "Menu/OK" (6) and "Down" (7) keys, and then switch the device back on (restore the voltage supply). When doing so, press and hold the keys until the display's backlight has been activated.



CAUTION!

Reset to default settings

All data will be deleted. All settings will be reset to the default settings (JUMO), including the user administration settings (user "Master", password "9200").

- ▶ Back up the hardware configuration and settings beforehand using the setup program.
-



NOTE!

Resetting to factory settings also removes the extra codes (chargeable functions). For this reason, the files for enabling the extra codes (also referred to as license files or FeatureResponse files) should be stored after initial receipt in such a way that they are available again for transfer to the device after a factory reset (see Web Cockpit > Service).

5 Operation

5.3 Setup program

5.3.1 Start page

The setup program is used to create new projects and edit existing projects.

The "Projects" window contains corresponding buttons. If applicable, the most recently edited and opened projects are also shown. These are likewise provided in the form of buttons for opening the respective project or switching to a project that is already open.

When creating a new project, a project template must be selected that depends on the device type and version of the device software. If necessary, the version of the setup program must also be taken into account.

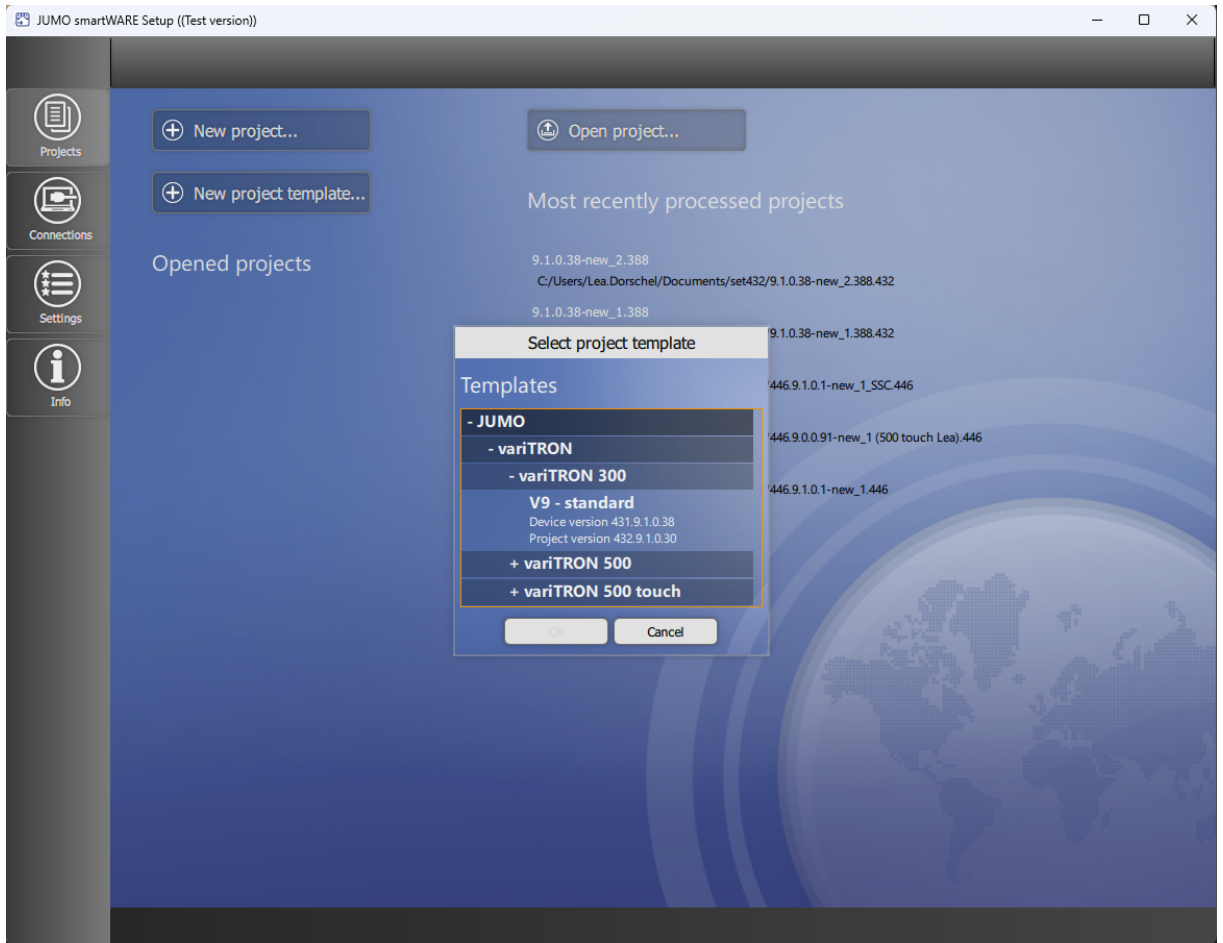

Functions provided in the left-hand bar (also known as the "application bar"):

- Projects: Create new project, import new project template (as of system version 8), open existing project
- Connections: Configure and manage connections to devices
- Settings: Select the language of the setup program
- Info: Display information about the setup program

The bar at the bottom also displays opened projects (in the form of "project maps").

NOTE!



Before a device (or system) can be put into operation, the setup program must be used to create a project and transfer it to the device. The first step is to define the hardware configuration for the device (type and arrangement of hardware modules). The connection to the device must also first be configured before the project can be transferred.

5.3.2 Project map

Create project using individual functions

The functions are combined in a project folder known as a project map.



The following functions are available within a project:

- **Project management:** Display the name and path of the project file, enter the designation and description of the project
- **HW-Assistent Systembus:** Define the hardware configuration for the entire system
- **Wtrans hardware assistant** (only for JUMO variTRON 300 and JUMO variTRON 500 touch): Define the hardware configuration for the entire system
- **Configuration:** Configure the device (central processing unit) and modules and determine their parameters
- **PLC application:** Determine the start parameters for the CODESYS PLC programming system, start the PLC configuration process (CODESYS)
- **PLC parameter definition:** The function is only available if the Configuration and Process Value Editor (CPVE) is installed determine the start parameters for the CPVE, start the CPVE
- **Languages:** Select the project language and device languages, export and import languages (texts)
- **Data transfer:** Establish a connection to a device, data transfer to/from the device, import and export the configuration
- **Messages** (as of system version 6): Display and edit project messages (acknowledge; other actions may be required)

You can access these functions using the tiles in the window and using the functions in the bar at the top (also known as the "project bar"). Selecting the "Project map" function takes the user back to the overview of functions.

5 Operation

5.3.3 Project management

Display project information, enter designation and description of the project, convert project



Parameters/functions:

- File name (non-editable): Project file name that was automatically assigned when creating the project.
- Path (non-editable): Path under which the project file has been saved.
- Project version (non-editable): Version of the setup project
- Device version (non-editable): Version of the device software
- Project designation (button): Opens a window for entering a designation for the project (in several languages).
- Description: Input field for providing a more detailed description of the project (in one language)
- Convert project (button): Convert project into the same or a higher system version (select project template); note messages!
- Validate project (button): Note messages!
- HTML export – export project into html format.

To change the file name and, if applicable, the file path, select the "Save as..." button.

5.3.4 System bus HW assistant

Defining the hardware configuration for the entire system

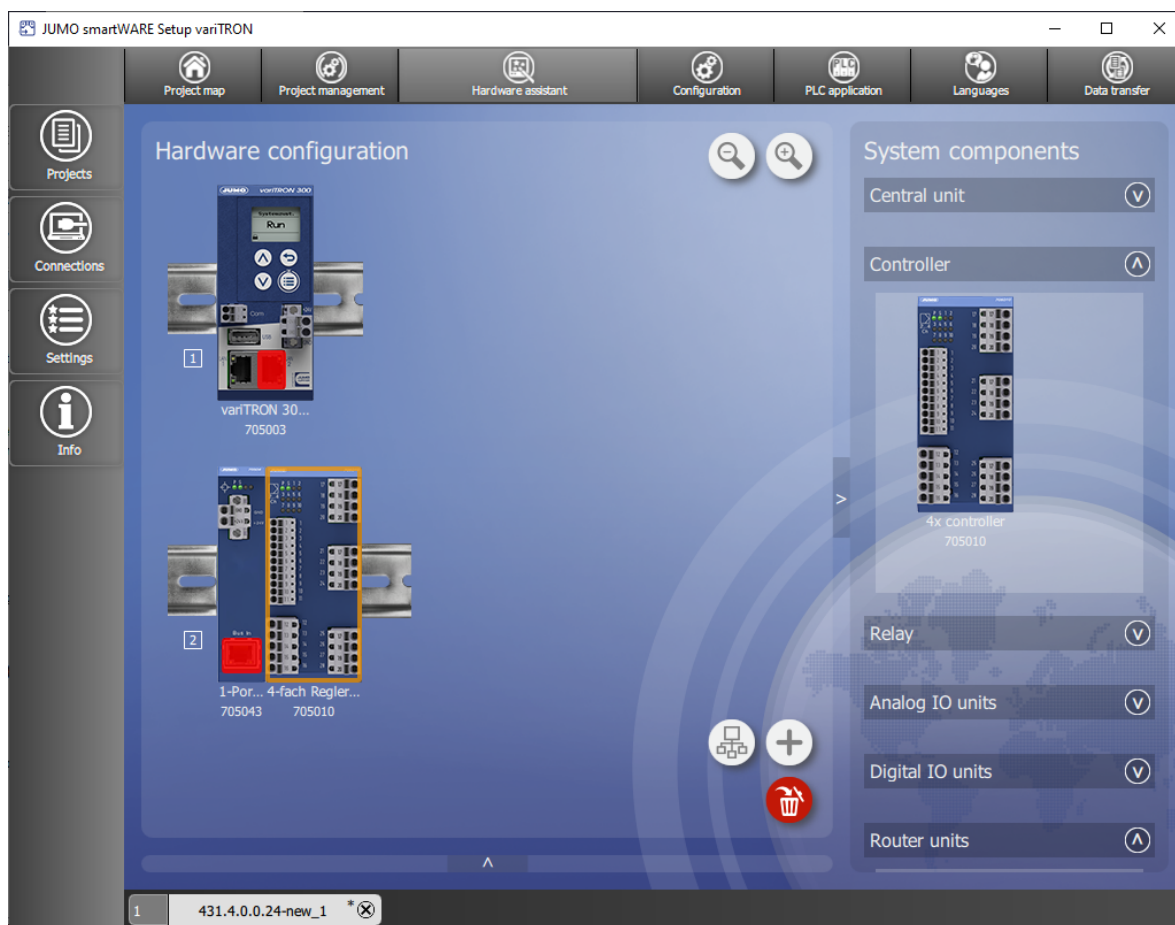

The window is separated into three areas:

- Hardware configuration
- System components
- Settings

To increase the size of the "Hardware configuration" area, the "System components" and "Settings" areas can be hidden by clicking the relevant button (right arrow/downward arrow).

Hardware configuration



NOTE!

As part of the hardware configuration, system components from the tried-and-tested JUMO variTRON series (7050xx) and the JUMO I/O system (7051xx) can be used separately or in combination. An adapter module 705171 must be used in the event of combined use of modules of JUMO variTRON (7050xx) and the JUMO I/O system (7051xx).

The "Hardware configuration" area shows the device (in this case the JUMO variTRON 300 touch central processing unit) and, if applicable, all previously added system components (modules). The view can be enlarged or reduced using the zoom function ("+" and "-" magnifying glass icons).

Since the variTRON 300 central processing unit does not have any side connections for voltage supply and system bus, a router module is required (primarily 1-port router module) to connect other modules. This router module must be placed on an additional DIN rail in the setup program. In a real system, it can be arranged on the same DIN rail as the central processing unit.

5 Operation

In the setup program, the connection between the router module and the central processing unit is established in the same way as the connection between router modules (see the following description). In the real system, a commercially available network cable is used (min. CAT5, S/FTP; connection to the LAN2 socket of the central processing unit).

The position of a module on the DIN rail can be changed by dragging and dropping the module accordingly.

Once selected, a module can be removed using the "Recycle bin" button or by pressing the Delete key on the keyboard (you can select the module by clicking on it; you can also navigate using the left/right arrow keys on the keyboard).

With the "+" button, the first DIN rail is adopted into the configuration. If necessary, additional DIN rails can be added (scroll down in the window to make the DIN rail visible). You can switch between the DIN rails using the Up/Down arrow keys on the keyboard. Empty DIN rails can be removed again using the "X" button.

The "Bus Scan" button is used to scan the system bus of the connected device and load the hardware configuration into the setup project.

System components

The "System components" area lists all available system components (open the drop-down menu by clicking on it). A distinction is made here between the central processing unit and the modules (controller, relay, analog IO units, digital IO units, router units). A thyristor power controller, adapter module for the I/O system, and end plates are available under "Various". A module can be added to the hardware configuration by dragging and dropping it or by double-clicking on the module. The central processing unit is specified by the setup program when creating a new project. The setup program displays the possible position of the system component as a white placeholder on the DIN rail. If the setup program does not display a white placeholder, it is not technically possible to use the component in this position. The position of a module on the DIN rail can be changed by dragging and dropping the module accordingly.



NOTE!

A maximum of 8 modules (up to system version 9) can be connected (router modules 7050xx and communication modules 7051xx do not count).

A maximum of 16 modules (as of system version 10) can be connected (router modules 7050xx and communication modules 7051xx do not count).

For this purpose, the transferred process values must be reduced to the minimum (active) in the process value map for the connection modules under Configuration > System bus > <Module name> > Device settings > Process values.

Settings

The "Settings" area displays information on the system component that is currently selected and enables certain settings to be configured:

- Product group number (non-editable)
- Designation (button): Opens a window for entering a designation for the system component (in several languages)
- Module label: Tag name for the system component (editable; can no longer be changed once the hardware configuration has been applied)
- Expansion slot (dependent on the module): For selecting the option (open the drop-down menu by clicking on it)
- Optional module (alias device address): ⇨ chapter 5.3.5 "Optional module (alias device address)", Page 49



NOTE!

If the hardware configuration is created with the "Bus scan" function, the setting of the rotary coding switches in the setup project must be checked in the case of a 3-port router module (705042) or 2-channel (705162)/3-channel (705163) I/O system communication module. If necessary, the setting must be changed before the configuration is sent to the device.

Router units

If the hardware configuration contains router units (router modules), these units must be connected with one another. To do so, proceed as follows (also applies to the connection between the variTRON 300 central processing unit and router module):

1. Click on a router module.
The free RJ45 sockets are depicted by a green border.
2. Double-click on a free socket (or on the "Start connection" connector icon on the right next to the socket).
*On the router module on the other DIN rail, suitable free sockets are depicted by a flashing green border. A distinction is automatically made here between inputs (Bus In) and outputs (Bus Out).
Please note: To cancel, click on the "Delete connection" x icon on the right next to the socket.*
3. Click on a free socket on the other router module (or on the "Close connection" connector icon on the right next to the socket).
*The connection between the two sockets is established (color change).
Please note: To delete the connection, click on the "Delete connection" x icon on the right next to one of the two sockets (or remove a router module)*
4. If necessary, establish connections to other router modules (connections are depicted by different colors for the relevant RJ45 sockets).

5.3.5 Optional module (alias device address)

Basic differences between the mandatory module and optional module

Mandatory module:

- The module must be available.
- The position of the module must correspond to the hardware arrangement in the setup program.

Optional module:

- Only router modules can be configured as the head module of an HC group (hot connect group or optional module group) (assignment of an alias device address).
- The router module and the components of its HC group (optional modules) need not be available.
- All input/output modules connected to it are also optional modules.
- Router modules connected to it are optional modules.
- Due to the alias device address, a router module is always uniquely identifiable within the system.
- The router module can be defined in the setup program with a fixed or a variable position on the system bus.

Differences at system start and during operation

System start:

- If a mandatory module causes a problem (module defective or not available, wrong position), the system will not start.
- The HC group must be completely available or completely missing. If only part of the HC group is available, the system will not start.

5 Operation

During operation:

- If a mandatory module fails or is removed, the entire system goes into the "Stop" state.
- If an optional module is used, the system continues to run.
- The HC group can be removed from the system and also connected again (hot connect functionality). If a part of the HC group is removed, the remaining modules of this HC group continue to run.

Configuration of optional modules

When creating a project with the setup program (hardware arrangement), all modules are initially mandatory modules. To form a line with optional modules (HC group), the relevant (upstream) router module must be configured as an optional module:

- 2-port router module (705041)

The "Optional" parameter must be set to TRUE (red) in the setup program.

The alias device address is fixed (0x200). Within a system, only a single 2-port router module can be configured as an optional module. In addition, no further 2-port router modules may be incorporated into the system.

Connected router modules are then also automatically optional modules (they do not have to be configured as optional modules themselves).

- 3-port router module (705042)

The rotary coding switches on the module must be used to set an alias device address (address not equal to 0). The same address must be set in the setup program using the parameters with the same name (rotary coding switch 10x, rotary coding switch 1x). If the settings do not match, the router module is not recognized on the system bus.

Note: if the alias device address 0 is set in the setup program, the address set on the router module is irrelevant (the addresses are not compared). The router module is then a mandatory module.

The alias device address is freely selectable, but must be unique within the system.

All input/output modules connected to the router module and any additional router modules are then also optional modules.

The router module as an optional module can also be operated at a system bus output that is not defined in the hardware arrangement. To prevent this possibility, the parameter "Fixed position" must be set to TRUE (red). Then the connection is only possible at the specific RJ45 socket of the specific router module as it corresponds to the hardware arrangement.

- 1-port router module (705043)

The "Optional" parameter must be set to TRUE (red) in the setup program.

The alias device address is fixed (0x100). Within a system, only a single 1-port router module can be configured as an optional module. In addition, no further 1-port router modules may be incorporated into the system.

Connected router modules are then also automatically optional modules (they do not have to be configured as optional modules themselves).

The router module as an optional module can also be operated at a system bus output that is not defined in the hardware arrangement. To prevent this possibility, the parameter "Fixed position" must be set to TRUE (red). Then the connection is only possible at the specific RJ45 socket of the specific router module as it corresponds to the hardware arrangement.

- 2-channel (705162) and 3-channel (705163) I/O system communication module

An alias device address (ECAT ID) can be set via the DIP switch in order to use the communication module as a so-called optional module. The alias device address is freely selectable, but must be unique within the system.

5.3.6 Wtrans HW assistant

Select Wtrans transmitters (wireless measured value transmission)



The window is separated into three areas:

- Transmitter configuration
- System components
- Settings

To increase the size of the "Transmitter configuration" area, the "System components" and "Settings" areas can be hidden by clicking the relevant button (right arrow/downward arrow).

Transmitter configuration

The "Transmitter configuration" area shows all previously added system components (Wtrans transmitters). The transmitters can be placed next to each other and under each other (self-expanding grid, scroll function horizontal and vertical). The view can be enlarged or reduced using the zoom function ("+" and "-" magnifying glass icons).

The position of a transmitter can be changed by dragging and dropping the module accordingly.

Once selected, a transmitter can be removed using the "Recycle bin" button or by pressing the Delete key on the keyboard (you can select the transmitter by clicking on it; you can also navigate using the left/right arrow keys on the keyboard).

System components

The "System components" area lists all available transmitters (open the drop-down menu by clicking on it). A transmitter can be added to the transmitter configuration by dragging and dropping it or by double-clicking on the transmitter.

5 Operation

Settings

The "Settings" area displays information on the system component that is currently selected and enables certain settings to be configured:

- Product group number (non-editable)
- Module label: Tag name for the system component (editable; can no longer be changed once the hardware configuration has been applied)
- Module designation (button): Opens a window for entering a designation for the system component (in several languages)

5.3.7 Configuration

Configure the device (central processing unit) and modules and determine their parameters



5 Operation

The "Configuration" area comprises the following areas (device-specific example shown):

- Network: Ethernet and port configuration
- Device manager: Device settings (device language, start-up behavior, partition change), device designations, time zone/NTP, date and time, customer-specific linearization (as of system version 5)
- Unit settings: Definition of the SI units used in the application
- System bus: Master (settings relating to the system bus; see below), module... (module-specific configuration parameters; see below)
- Data carrier management (as of system version 7): Use of network drives
- System status UI (only with JUMO variTRON 300 and JUMO variTRON 500): Screensaver (activation and waiting period)
- User interface (only for JUMO variTRON 500 touch): Setting the boot logo, activation of screensaver, setting of screen brightness and screen orientation
- Web server: Activation, HTTP or HTTPS, port numbers
- Email: Settings for sending emails
- PLC configuration: Configuration of program generators, analog and digital variables (as of system version 5)
- PLC Parameter: Display of the configuration structures created using the Configuration and Process Value Editor (CPVE)
- Programs: Creation of programs using the program editor (setpoint values, operating contacts)
- CODESYS configuration: Definition of the automatic storage interval for retain data
- Recorder: Definition of groups and customization of the group-specific display modes
- Recording data export (as from system version 6): Configuration of the connection to the database
- Cloud gateway: Configuration of the connection to JUMO Cloud (as of system version 4)
- Signal generator: Specification of analog and digital signals within the system
- Wtrans gateway (only with JUMO variTRON 300 and JUMO variTRON 500 touch): Settings for using the JUMO Wtrans transmitters (as of system version 5)
- Node-RED (as of system version 4): Activation of the development tool Node-RED
- Batches (as of system version 6): Configuration of batch reporting

Details can be found in the "Configuration" chapter.

⇒ chapter 6 "Configuration", Page 83



NOTE!

The settings configured under "System bus > Master" influence the transfer of data via the system bus. Sub-optimal settings here will disrupt or even interrupt communication within the system. For this reason, these parameters are only permitted to be modified by a service engineer from the device manufacturer (or by someone acting on their instructions).

The process of configuring the modules (controllers, relays, analog IO units, digital IO units) is described in the operating manual for the respective module.

⇒ chapter 1.8 "Available technical documentation", Page 15

5.3.8 PLC application

Determine the start parameters for the CODESYS PLC programming system, start CODESYS



Parameters/functions:

- Start to debug: Start CODESYS without a newly created device description (the compilation process is not run again before logon, the program is not stopped when logging on to the target system)
- Install plugin: Newly initialize the CODESYS plug-in (e.g., after uninstalling and reinstalling CODESYS)
- Programming system: Select the CODESYS version (drop-down menu)
- Most recently edited with programming system (display only): Most recently used CODESYS version
- As of programming system (display only): Version of the CODESYS runtime system in the device during the last execution
- Provide import environment: Provide texts from the "PLC Parameter" configuration area for import (after starting the PLC configuration)
- Import of a project archive (as of system version 8): Select CODESYS file of type ".projectarchive" for import.

To start the programming system, click the "Start CODESYS" button.

5 Operation

5.3.9 PLC parameter definition

Determine the start parameters for the CPV Editor (CPVE), start the CPVE

This function is only available if the CPV Editor has been installed.



NOTE!

The CPV Editor is used to create customer-specific configuration and process data.

The CPV Editor requires specific knowledge and is intended for use by the manufacturer only (service that is subject to a fee).

A description of the CPV Editor is not included in this operating manual.

5.3.10 Languages

Select the project language and device languages, export and import languages (texts), edit languages

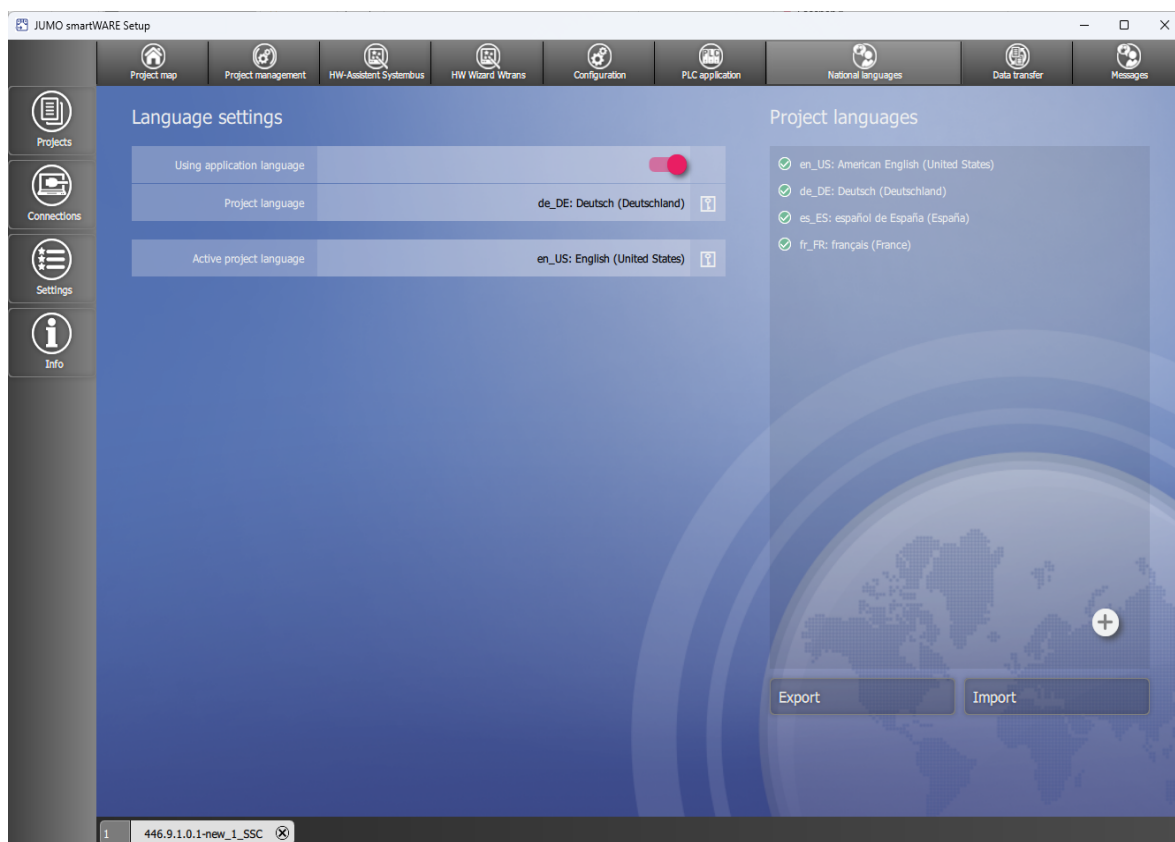

Language settings

Parameters/functions:

- Use application language: Use the language of the setup program as the project language
- Project language (button; not active if the application language is being used): Select the project language from the list (drop-down menu)
- Active project language (cannot be set here): Displays the current project language

5 Operation

Project languages

Parameters/functions:

- List: Project languages which are available for selection as the device language
 - Language selected (checked): Language can be selected in the device
 - "+" button: Add another language to the list of project languages
 - Delete a project language: Click on the "x" icon after the highlighted language
- Export: Export texts from a language to a language file (*.ts) for translation
 - Select the source language for the translation (the language "Standard" exports all default texts of the so-called development language)
 - Select the target language (if necessary, add your desired target language to the list of project languages beforehand)
- Import: Import translated texts (source language > target language) from a language file (*.ts)
 - Open a language file: Select the language file from the file directory (the source language, target language, and number of texts are displayed)
 - Load a language file: Import texts (the number of texts before and after the import is displayed)
- Start Linguist (only if the Configuration and Process Value Editor – CPVE is installed):
Edit language files with the "Qt Linguist" editor
 - File > Open: Select, open, and edit language file from the file directory

5.3.11 Data transfer

Establish a connection to a device, data transfer to/from the device, import and export the configuration

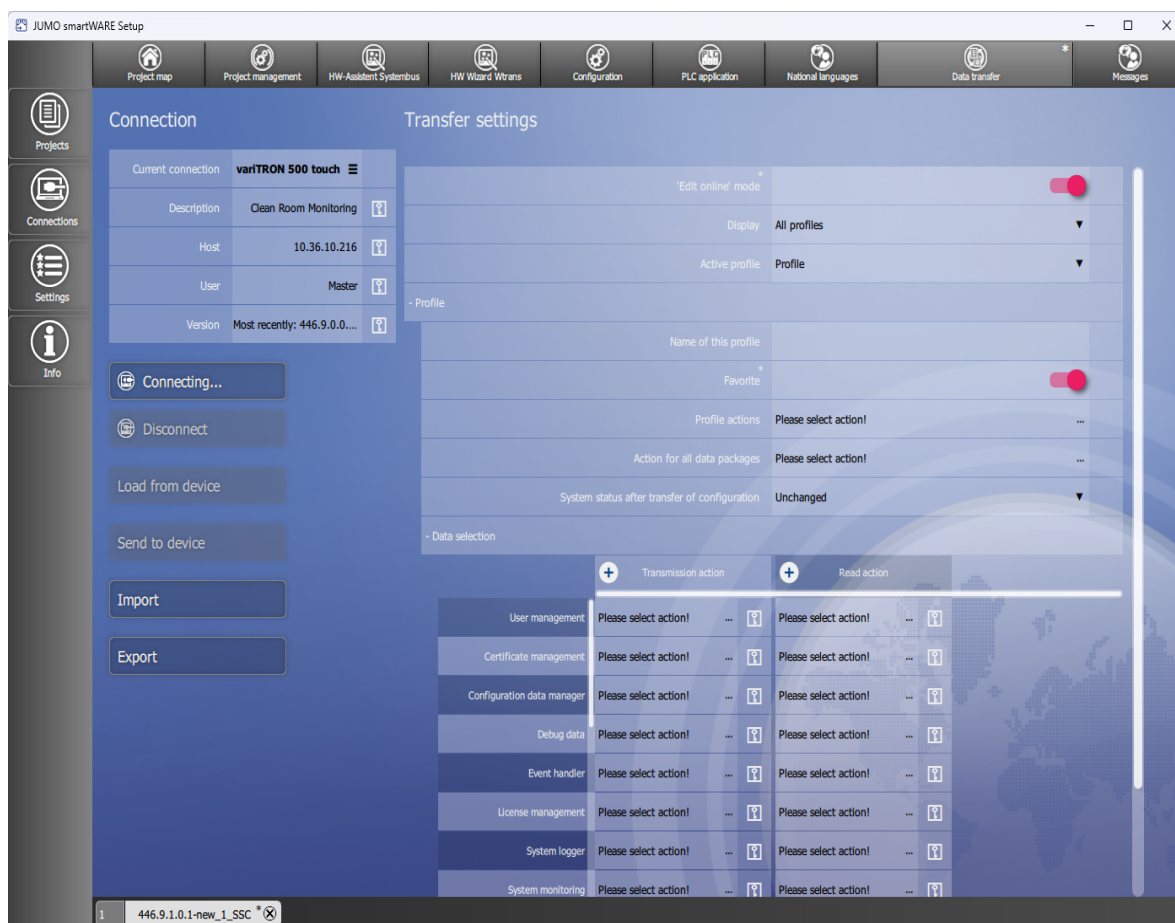

Connection

Parameters/functions:

- **Current connection (button):** Displays the current connection; if necessary, select a different connection from the list
- **Description (cannot be edited here):** Description of the current connection
- **Host (cannot be edited here):** IP address of the device
- **User (cannot be edited here):** User name for logging on to the device
- **Version (cannot be edited here):** Device software of the connected device
- **Connecting...:** Establish a connection to the device
- **Disconnect:** Break the connection
- **Load from device:** Load a configuration from the device into the setup program
- **Send to device:** Send a configuration from the setup program to the device
- **Import:** Select a configuration file (.jcf) from the file directory on the PC and import it into the setup program
- **Export:** Save a configuration as a file (.jcf) in the file directory on the PC

In order for a connection to be available for selection here, it must first be configured using the "Connections" function (application bar).

5 Operation

Transfer settings

Parameters/functions:

- "Online editing" mode (from system version 8): direct editing of the configuration during active operation.
- Display (from system version 9):
 - All profiles: All saved transfer profiles are displayed.
 - Favorites only: All transfer profiles marked as favorites are displayed.
- Active profile (as of system version 9):
 - Profile: The settings from the active profile are used when executing the action buttons (e.g. "Load from device").
- Name of this profile (as of system version 9): Input field for the profile name (unilingual).
- Favorite (as of system version 9): Mark a transfer profile as a favorite.
- Profile actions (as of system version 9):
 - Add new profile: A new profile is added.
 - Duplicate this profile: The active profile is duplicated.
 - Delete this profile: The active profile is deleted.
- Action for all data packets (as of system version 9):
 - Send to device: Only data for the options selected are sent to the device.
 - Extract from device: Only data for the options selected are transferred out of the device.
 - Export to *.jcf: Only data from the selected options are copied to a *.jcf file.
 - Import from *.jcf: Only data from the selected options are transferred out of a *.jcf file.
 - Import from an open project: Only data from the selected options are transferred out of another open project in the setup program.
- System status after transfer of configuration (as of system version 5):
 - Unchanged: After the transfer is complete, the device returns to the system status from before the transfer.
 - Stop: The device remains in the "Stop" system status after the transfer is complete.

Data packets

The following data packets are available:

- User management (AccessControlManager)
- Certificate administration (as of system version 9)
- Configuration data manager (as of system version 9)
- Debug data (as of system version 9)
- Event handler (as of system version 9)
- License management (as of system version 9)
- SystemLogger (as of system version 9)
- System monitoring (as of system version 9)
- Firmware update (as of system version 9)
- Device manager
- Unit settings (as of system version 10)
- System bus
- Data carrier management (as of system version 7)
- Port configuration (as of system version 8)
- Ethernet
- User interface (only with JUMO variTRON 500 touch)
- Web server
- Email
- PLC configuration
- CODESYS configuration
- Controller app (as of system version 10)
- PLC parameters
- PLC parameter 2 up to PLC parameter 4 (as of system version 7)
- Programs
- System status UI (only with JUMO variTRON 300, JUMO variTRON 500)
- Real-time processing (as of system version 6)
- Recorder (as of system version 9)
- Recording data export (as of system version 6)
- Cloud gateway (as of system version 4)
- Signal generator (as of system version 9)
- Wtrans gateway (only with JUMO variTRON 300, JUMO variTRON 500 touch)
- Node-RED (as of system version 3)
- Batches (as of system version 6)
- UI resources (as of system version 9)
- System management (as of system version 10)
- System status (as of system version 10)

5 Operation

Send and read actions

For each data packet, send and read actions can be selected from the respective dropdown menu. If an action is marked with a lock icon, the associated options are disabled via the slider. If at least one of the sliders is activated, a send or read action can be selected. Options with a lock icon are not available for the data packet in question and cannot be activated.



NOTE!

The default settings are suitable for most application scenarios and should only be modified by experienced users.

	Transmission action	Normal configuration	Device-specific	National languages	Other files	Read action	Visible values	Hidden values
User management	Please select action! ...	<input type="checkbox"/>	<input type="checkbox"/>	<input type="checkbox"/>	<input type="checkbox"/>	Please select action! ...	<input type="checkbox"/>	<input type="checkbox"/>
Certificate management	Please select action! ...	<input type="checkbox"/>	<input type="checkbox"/>	<input type="checkbox"/>	<input type="checkbox"/>	Please select action! ...	<input type="checkbox"/>	<input type="checkbox"/>
Configuration data manager	Please select action! ...	<input type="checkbox"/>	<input type="checkbox"/>	<input type="checkbox"/>	<input type="checkbox"/>	Please select action! ...	<input type="checkbox"/>	<input type="checkbox"/>
Debug data	Please select action! ...	<input type="checkbox"/>	<input type="checkbox"/>	<input type="checkbox"/>	<input type="checkbox"/>	Please select action! ...	<input type="checkbox"/>	<input type="checkbox"/>
Event handler	Please select action! ...	<input type="checkbox"/>	<input type="checkbox"/>	<input type="checkbox"/>	<input type="checkbox"/>	Please select action! ...	<input type="checkbox"/>	<input type="checkbox"/>
License management	Please select action! ...	<input type="checkbox"/>	<input type="checkbox"/>	<input type="checkbox"/>	<input type="checkbox"/>	Please select action! ...	<input type="checkbox"/>	<input type="checkbox"/>
System logger	Please select action! ...	<input type="checkbox"/>	<input type="checkbox"/>	<input type="checkbox"/>	<input type="checkbox"/>	Please select action! ...	<input type="checkbox"/>	<input type="checkbox"/>
System monitoring	Please select action! ...	<input type="checkbox"/>	<input type="checkbox"/>	<input type="checkbox"/>	<input type="checkbox"/>	Please select action! ...	<input type="checkbox"/>	<input type="checkbox"/>
Firmware update	Please select action! ...	<input type="checkbox"/>	<input type="checkbox"/>	<input type="checkbox"/>	<input type="checkbox"/>	Please select action! ...	<input type="checkbox"/>	<input type="checkbox"/>
Device manager	Please select action! ...	<input checked="" type="checkbox"/>	<input type="checkbox"/>	<input checked="" type="checkbox"/>	<input type="checkbox"/>	Please select action! ...	<input checked="" type="checkbox"/>	<input checked="" type="checkbox"/>
Unit settings	Please select action! ...	<input checked="" type="checkbox"/>	<input type="checkbox"/>	<input checked="" type="checkbox"/>	<input type="checkbox"/>	Please select action! ...	<input checked="" type="checkbox"/>	<input checked="" type="checkbox"/>

Send action:

- Normal configuration: All parameters used to configure a module. Not all modules have configuration parameters.
- Device-specific: Parameters that are configured in the device manager, ⇨ Seite 53. Only a few modules have device-specific parameters. These are marked in the configuration.
- Languages: Module texts in the configured language, ⇨ Seite 57.
- Other files: Module files, e.g. databases, single page applications or CPVE projects.

Read action:

- Visible values: Visible parameters that configure the module.
- Hidden values: Hidden parameters that configure the module.
- Write-protected values: Write-protected parameters that configure the module.
- Modify structure: Enables the project's structure to be adapted to the device structure.
CAUTION! Modules may be removed when deleting or creating system bus modules.
- Device-specific: Parameters that are configured in the device manager, ⇨ Seite 53. Only a few modules have device-specific parameters. These are marked in the configuration.
- Languages: Module texts in the configured language, ⇨ Seite 57.
- Other files: Module files, e.g. databases, single page applications or CPVE projects.



CAUTION!

While the configuration is being sent to the device, the device enters the "Stop" system status.

This interrupts execution of the PLC application.

- ▶ The user must ensure that this does not have any negative impacts on the system's active operations.

5.3.12 Messages

Display and act on project messages



Project messages that require user action (acknowledge message, perform further actions if necessary) are displayed here.

5 Operation

5.3.13 Connections

Connection list

Configure a connection to a device; overview of all configured connections

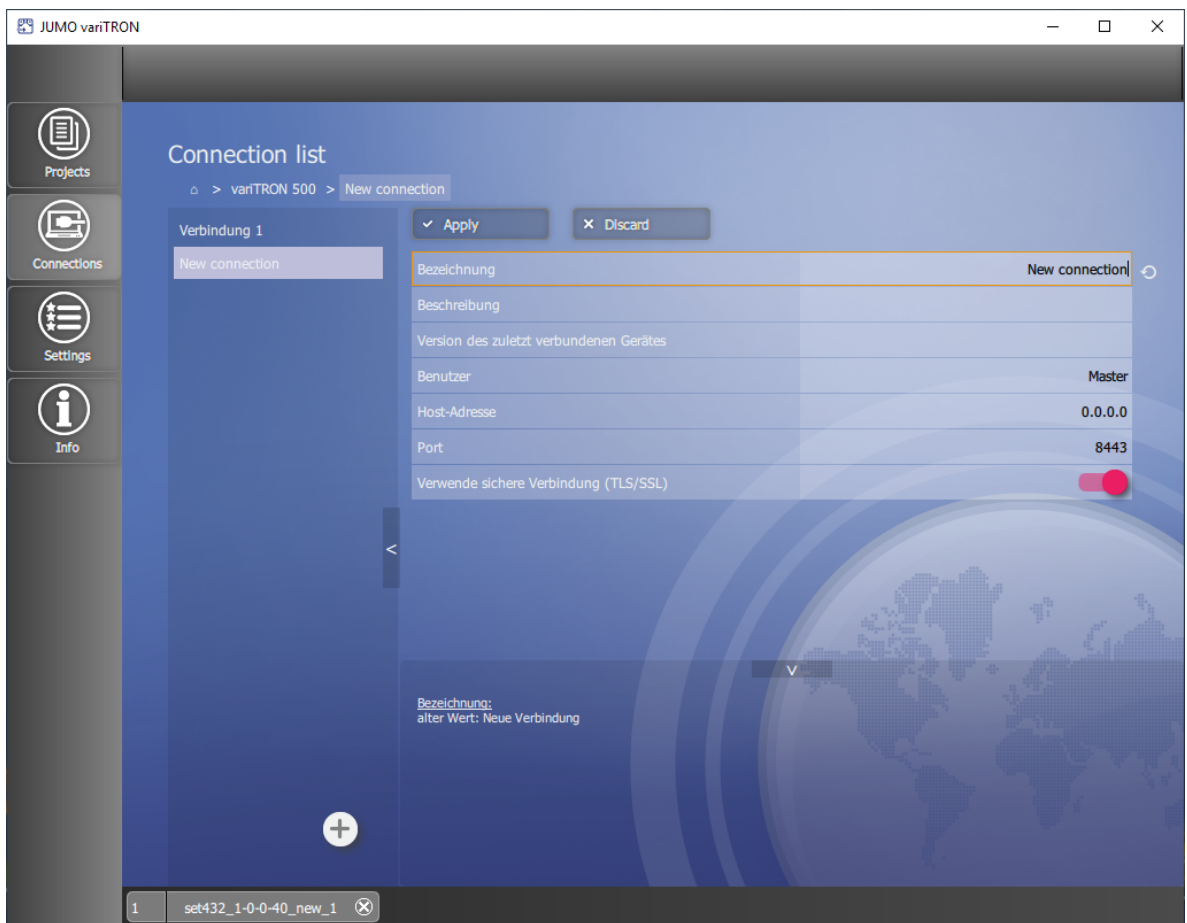

Parameters/functions:

- Designation (editable): Freely selectable designation for the connection
- Description (editable): Text for a more detailed description of the connection
- Version of most recently connected device: Version number of the device software
- User (editable): User name for logging on to the device
- Host address (editable): IP address of the device
- Port (editable; default setting is 443): Port number for the connection using the setup program
- Use secure connection (TLS/SSL): FALSE (gray = no), TRUE (red = yes, default setting)
This setting affects the port numbers for the connection (see above). The following port numbers have been assigned per default: 80 for FALSE (HTTP), 443 for TRUE (HTTPS).
⇒ chapter 6.8 "Web server", Page 94
If a port number is changed in the configuration, it must also be changed here under "Port".
- Discard: Discard all data entries made
- Apply: Save all values

The left-hand side of this window lists all configured connections along with their designation. You can add another connection using the "+" button. To remove a connection, click the "x" in the area with the designation (this is activated when the cursor is on the area).

If applicable, the old value of the parameter that has just been changed is shown at the bottom of this window. Clicking the "Back" button (circular arrow) after the line containing the changed parameter (above) discards your data entry.

Both areas can be hidden by clicking the relevant button (arrow).

5 Operation

5.4 Web Services

Web Services enables the device to be accessed using a web browser. The landing page provides system information and multiple web applications such as Web Cockpit and WebVisu with its tiles. The following web browsers are supported: Mozilla Firefox, Google Chrome, Microsoft Edge, Opera



NOTE!

JUMO has successfully tested the aforementioned web browsers using Microsoft®Windows® 10. If you use a different web browser or another operating system, JUMO cannot guarantee that the function will work correctly.

To start the web application, you need to enter the device's IP address in the address line of the web browser (example: 10.178.59.209). The IP address is displayed on the device connected by LAN under "/Applications/System management/Device info/Ethernet/LAN1 or LAN2".

The web browser accesses the device with HTTPS (Hypertext Transfer Protocol Secure) via an encrypted connection. You will need your user name and password to log on to the device. Once you have successfully logged on, the JUMO Web Services landing page is shown.

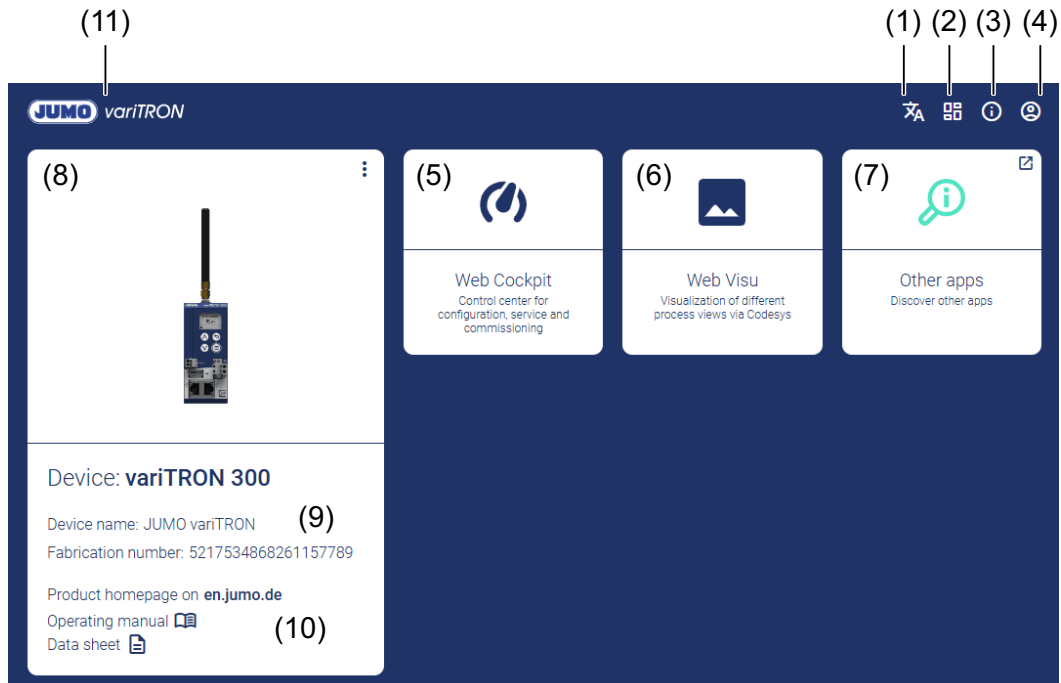

1	National language selection	7	Link to the JUMO Help Center
2	Direct access to the landing page functions	8	Info tile
3	Links to various information <ul style="list-style-type: none"> • Web application version info • License information • Link to the JUMO Help Center 	9	Display device name and fabrication number
4	<ul style="list-style-type: none"> • Info about the logged-in user • Flash display • Log out 	10	Links to <ul style="list-style-type: none"> • JUMO product homepage • Operating manual and data sheet
5	Opens the Web Cockpit	11	Return to landing page
6	Only for devices with CODESYS WebVisu: Opens the CODESYS WebVisu of the device in the browser		

5.4.1 Web Cockpit

The Web Cockpit is a web application that enables operation similar to operation on the device. Operation in the Web Cockpit is higher performance and expanded to include several extra functions.

Start page

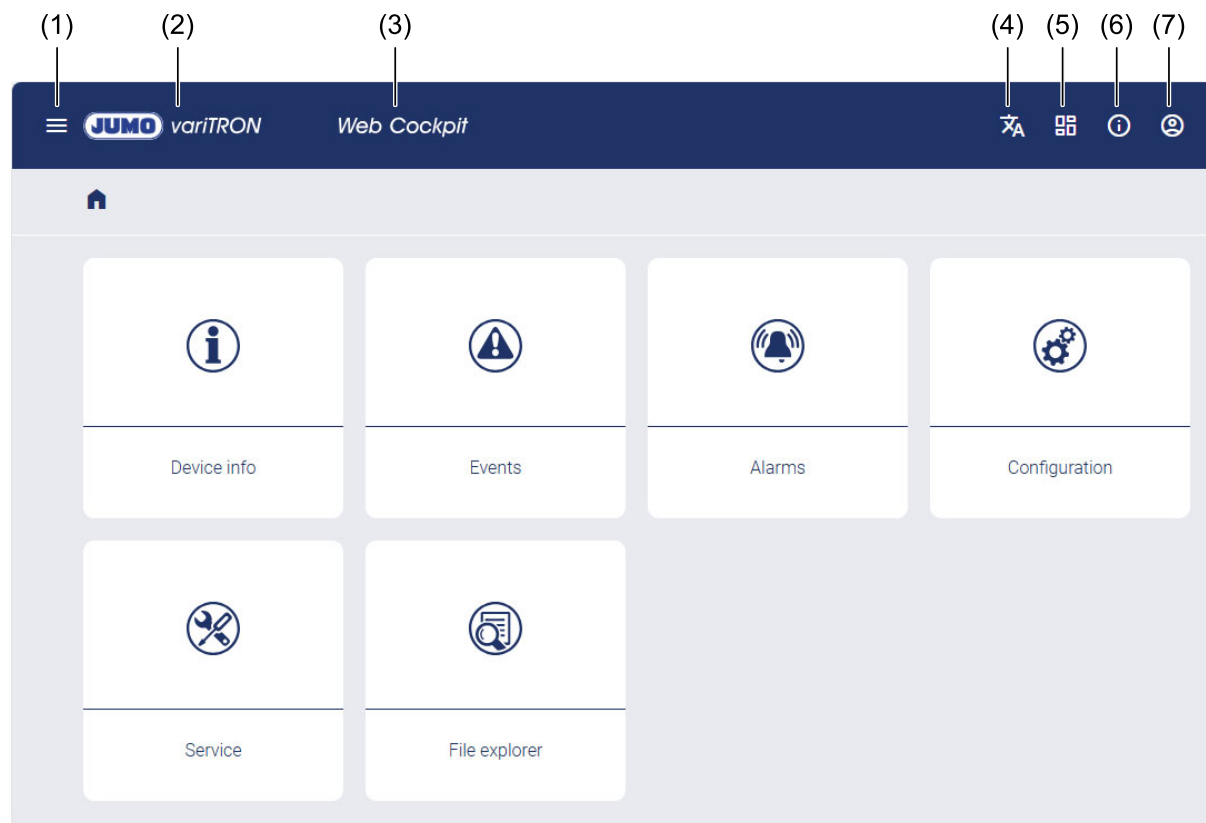

The functions in the landing page header have been expanded to include three functions on the Web Cockpit homepage. The Web Cockpit functions can be called up using both the tiles on the homepage and via the Web Cockpit menu.

1	Opens the Web Cockpit menu – see below	5	Web applications – see details below
2	Return to landing page	6	Links to various information <ul style="list-style-type: none"> • Web application version info • License information
3	Return to the Web Cockpit homepage	7	User – see details below
4	National language selection		

5 Operation

Designation	Description
Device info	Status, versions, certificates... <ul style="list-style-type: none"> • Certificate management (display certificates) • Cloud gateway (status, version) • Recording data export (export status, version) • Display device information • License management (display extra codes) • Display Ethernet parameters • Real-time processing (display information on data recording) • PLC application (display information) • PLC runtime environment (display information) • System monitoring (battery, storage, temperatures, voltage values) • Display and change the system status (Run, Stop, etc.) • Only with JUMO variTRON 300 and JUMO variTRON 500 touch: Wtrans gateway (version, radio frequency, Wtrans transmitter)
Events	Events, alarms, audit trail, etc. <ul style="list-style-type: none"> • Messages (events) shown in a list • Plain-text search • Filter by message type (type) • Filter by keywords • Delete messages/update list
Alarms	Alarms, acknowledgment, etc. <ul style="list-style-type: none"> • Messages shown in a list • Filter by message type • Filter by alarm or fault • Plain-text search • Acknowledge alarms/update list
Configuration	Configure modules, etc. <ul style="list-style-type: none"> • Configure device • Configure connected modules (system bus)
Service	System bus, users, firmware <ul style="list-style-type: none"> • EtherCAT (system bus): Display information on the master and slaves (modules); perform actions • Only with JUMO variTRON 300 and JUMO variTRON 500 touch: Wtrans gateway (status of the transmitters) • User management: Create users, assign roles • Import configuration: Transfer configuration file (.jcf) to the device • Extract configuration: Extract configuration from the device and save it as a file (.jcf) • Function activation: Activate extra codes • Firmware: Update the device firmware • Log list: Extract log entries from the device • Debug: Extract debug data from the device and create a debug file (.jdf) • Import or replace certificates • Screenshot, create device screenshot
File explorer (as of system version 7)	Files and folders <ul style="list-style-type: none"> • Files in "Shared Folder" • Create folder, upload files, update view

"Menu" button

The functions on the homepage can also be accessed using the "Menu" button:

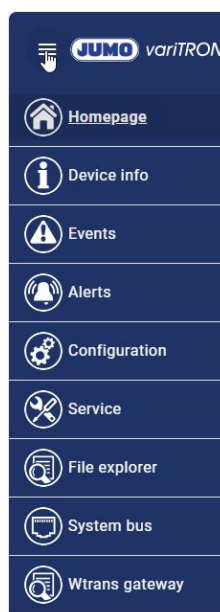

Selecting the menu item "System bus" accesses the function "Service > System bus" directly.

Only with JUMO variTRON 300 and JUMO variTRON 500 touch: The function "Service > Wtrans gateways" is called up directly using the menu item "Wtrans gateway".

"User" button

The previous functions (except information and license information) are available under the "User" (right) button.

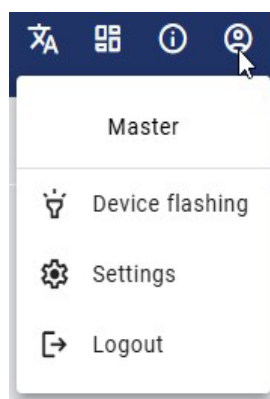

Designation	Description
Master	The user name of the logged-on user is displayed here.
Device flashing	The device display flashes (in particular if multiple JUMO variTRONs are used for identification).
Settings	Change password
Logout	Log off user

5 Operation

"Web applications" button

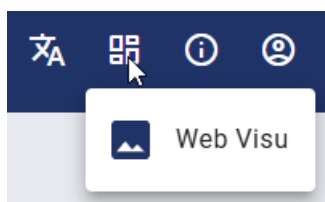

Using the new "Web applications" button, the user can switch to other active web applications (for example "CODESYS WebVisu").

Device information

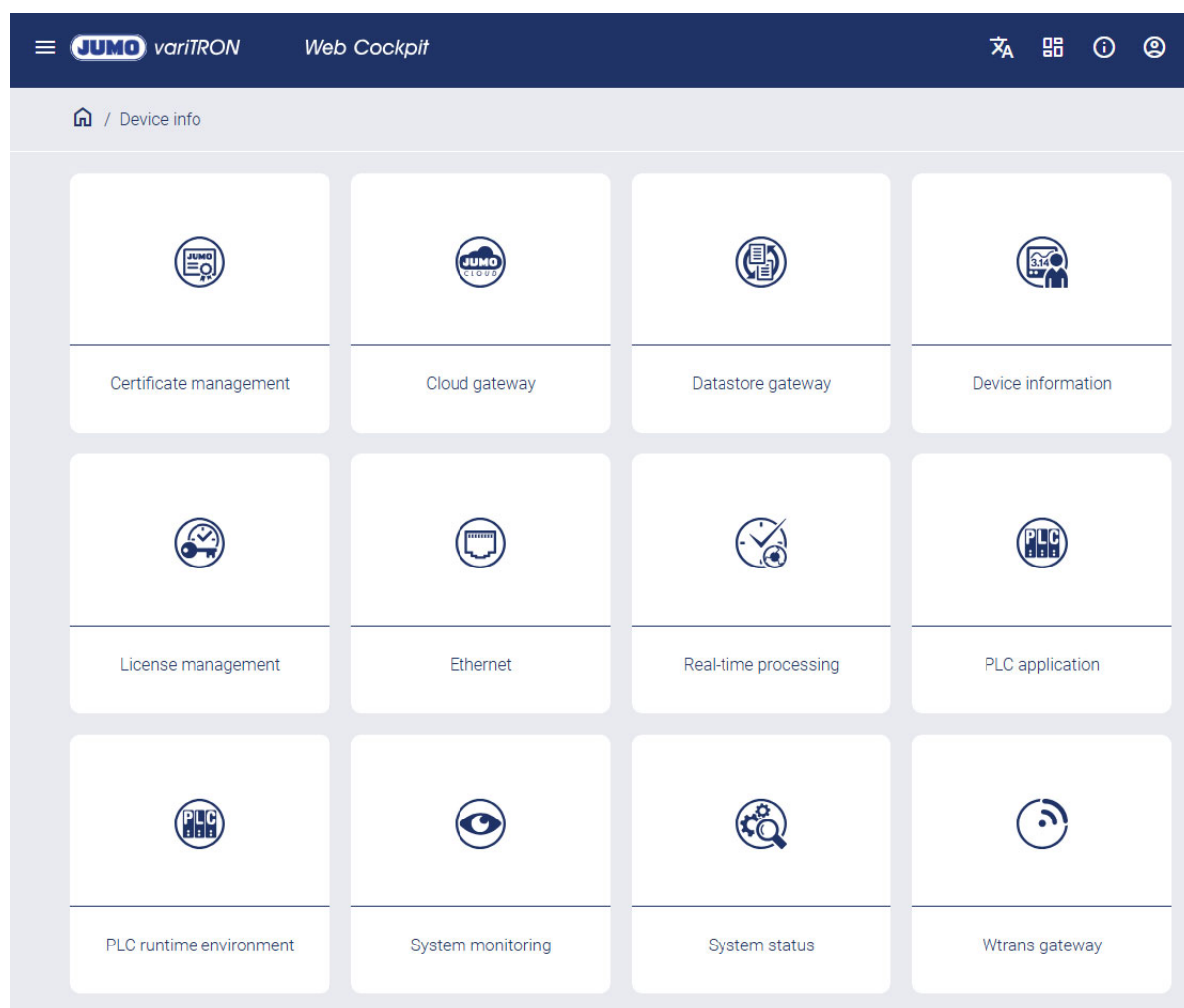

Certificate management

The following certificates are displayed here:

- Data recording
- Web gateway

Cloud gateway

There are the two tiles "State" and "Version". The cloud gateway's status and memory usage are displayed under "State". "Version" displays the cloud gateway version.

The following functions are displayed under the "State" tile:

- DELETE CONFIG. (as of system version 8.1)
 - Deletes the configuration received from the server (signals and data connections).
- CLEAR BUFFER (as of system version 8.1)
 - Deletes the buffered data.
- DELETE ALL (CLEAR)
 - Deletes the buffered data and the configuration received from the server.
- REBOOT
 - Restarts the cloud gateway.

5 Operation

Recording data export

There are the "Export Status", "Export information", and "Version" tiles. Configuration is carried out in the setup program.

The following information is available under "**Export Status**":

- Memory usage / data export active or inactive
- Storage location on the web / date of the last export
- Recording: Status of the data recording and date and time of the last recording.

New function as of system version 8: Manual export of the recorded data (for example for backing up before a firmware update). The date of the last export is displayed.

The "Delete data record" function can be used to delete the recorded data.

The following information is available under "**Export information**":

- Export status: Memory usage / data export active or inactive
- Database information also under "Database"
 - Level
 - Number of channel entries
 - Number of process data entries
 - Number of group configurations
 - Number of DeviceDescription entries
 - Max. ID for cyclical data
 - Current export ID (cyclical)

The database version is displayed under the "**Version**" tile.

Device information

There are the "Device", "Hardware versions", and "Software versions" tiles.

The device name, device-specific numbers, and version numbers for hardware and software components in the device are displayed here.

Information on the connected modules is not displayed here. This information can be accessed using the function "Service > System bus".

License management

The CODESYS extra codes and their statuses are displayed under the "Extra code" tile (active = extra code is active and can be used).

Ethernet

Information on the Ethernet interfaces LAN1, LAN2 and, if necessary, LAN3 is displayed here. The LAN1 and LAN2 tiles are available as standard. Values are only displayed for active LAN connections.

Real-time processing

Information on the data recording (thread runtime, cycle counter, timeout counter, wakeup deviation) is displayed under the "Data recording" tile.

The "Reset time measurement" function can be used to reset and restart the time measurement.

PLC application

The versions of the PLC applications are displayed under the "Versions" tile.

PLC runtime environment

Version information on the PLC runtime environment and the status of the exception handler are displayed here.

System monitoring

There are the "Battery status", "Memory", "Performance", and "Temperature" tiles here.

Information on the system battery status, memory usage, CPU and RAM utilization, and CPU temperature is displayed here.

Memory and temperature tiles: The "Reset drag indicator" function can be used to reset the resettable minimum and maximum values.

System status

The current system status is displayed here.

Corresponding functions are available to change the system status:

- REBOOT SYSTEM (as of system version 5)
 - Restart of the central processing unit.
- ORIGIN RESET
 - An "Origin" reset resets the system bus (master restarts, data of the modules on the bus is loaded again) and deletes the bus configuration.
 - The PLC performs a full reset, which means that the PLC program and the retain area¹ are deleted (see CODESYS documentation on origin (full reset) of PLC).
 - An event message is issued (origin reset).
- COLD RESET
 - The PLC performs a cold start, which means that the retain area¹ is deleted (see CODESYS documentation on PLC cold start).
 - An event message is issued (cold start reset).
- RESET
 - The PLC performs a warm start, which means that the retain area¹ is retained (see CODESYS documentation on PLC warm start).
 - An event message is issued (warm start reset).
- STOP
- RUN

Wtrans gateway (only with JUMO variTRON 300 and JUMO variTRON 500 touch)

Information on the Wtrans gateway is displayed here (version, radio frequency; Wtrans transmitter: e.g. transmitter ID, battery state, RSSI value; measured value, transmission interval).

¹ JUMO variTRON 300: Retain handling only possible via sync in CODESYS (JUMO Library available as of system version 6).
JUMO variTRON 500 touch: Retain handling only possible via sync in CODESYS (JUMO Library available as of system version 6) and with basic type extension 5 = "without UPS".

5 Operation

Events

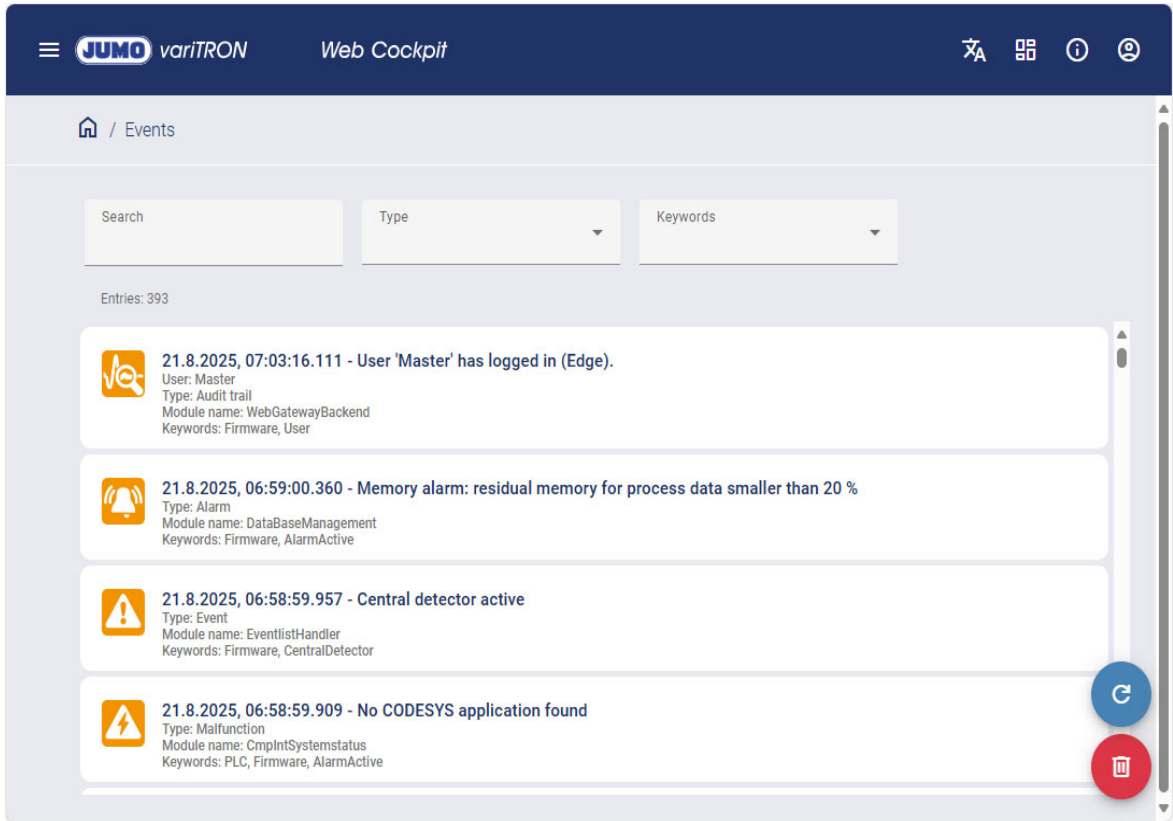

Event messages are extracted from the device and listed in chronological order here.

The information shown can be filtered by message type (alarm, audit trail, malfunction, event). It is also possible to search for specific keywords and run a full-text search.

The "Refresh" function (button) refreshes the list.

The "Delete" function (button) deletes all entries from the list in the device.



NOTE!

The different types of event messages are organized in a common ring buffer. In the event that old entries are overwritten, it is usually ensured that audit trail messages remain stored for at least 14 days.

Alarms

Alarm messages are extracted from the device and listed in chronological order here.

The information shown can be filtered by message type (alarm, malfunction). It is also possible to search for specific keywords and run a full-text search.

The "Refresh" function (button) refreshes the list.

The "Confirm" function (button) acknowledges an alarm. For this purpose, the relevant alarm must be selected (ticked) beforehand.

Configuration

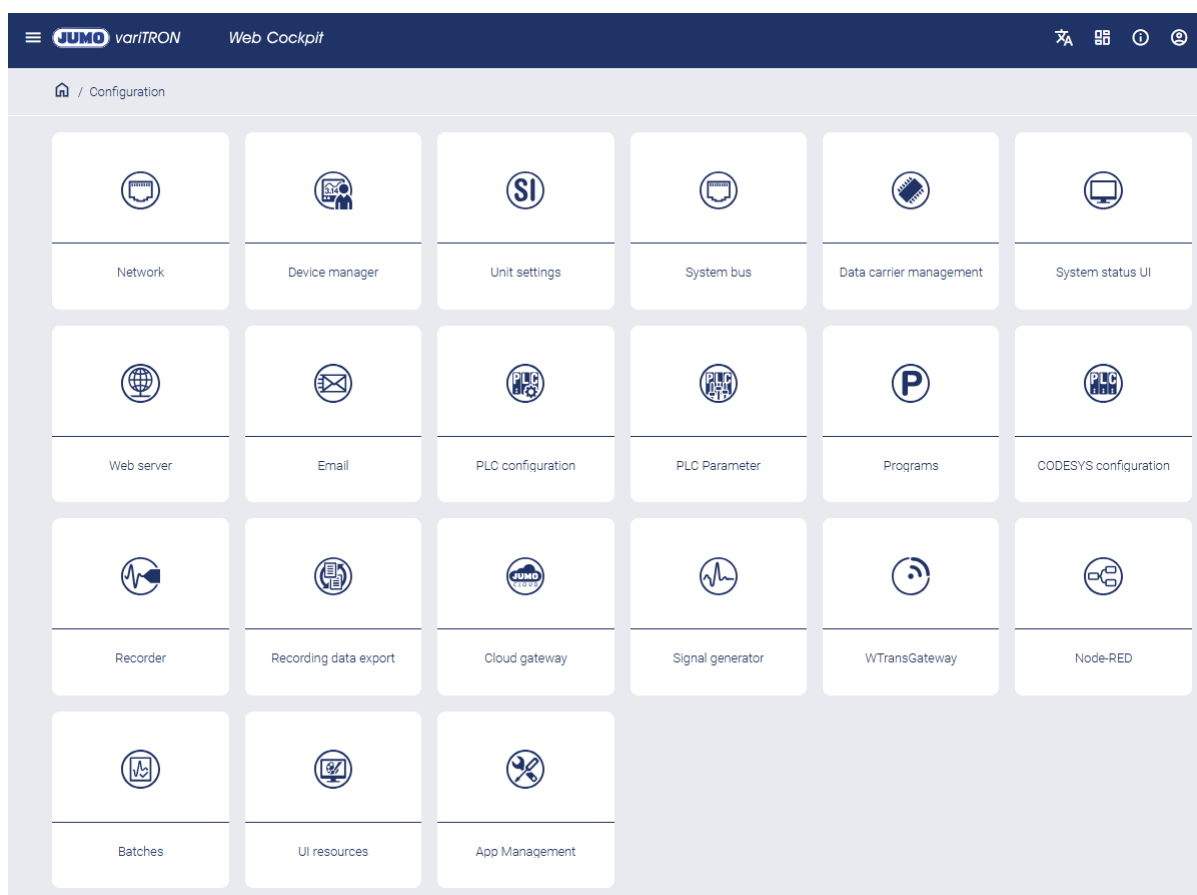

The following sections are merely intended to provide an overview of the functions which are configured under the respective tile.

The process of configuring the individual functions in the central processing unit (master) is described in detail in the "Configuration" chapter in this document.

⇒ chapter 6 "Configuration", Page 83

The process of configuring the modules (controllers, relays, analog IO units, digital IO units) is described in the operating manual for the respective module.

⇒ chapter 1.8 "Available technical documentation", Page 15

Network

The Ethernet interface LAN1 and, if applicable, other Ethernet interfaces (LANx) are configured here.

The Ethernet interface (LANx) to be used as the PROFINET port (available as of system version 8) is selected under "Port configuration".

Device manager

Here, device settings are configured (device language, start-up behavior, partition change), device designations are assigned, the time zone and time server are selected, and the date and time are manually set. The customer-specific linearization is also configured here (as of system version 5). The colors for displaying alarms can be defined under "Display".

Unit settings

The SI units used in the system can be defined and set here.

5 Operation

System bus

The "Master" tile is where settings relating to the transfer of data via the system bus are configured.



NOTE!

The settings configured under "Master" influence the transfer of data via the system bus. Sub-optimal settings here will disrupt or even interrupt communication within the system. For this reason, these parameters are only permitted to be modified by a service engineer from the device manufacturer (or by someone acting on their instructions).

The modules connected via the system bus are each depicted by a separate tile, which takes the user to the module configuration.

The tile can be disabled under "App management".

Data carrier management

Settings for the use of network drives are configured here (available as of system version 7).

System status UI

The screensaver is configured here.

Web server

The web server function is configured here.

Email

The settings for sending emails are configured here.

The tile must be activated under "App management".

PLC configuration

Here, the units for absolute and relative temperature values are determined (for the PLC application), the program generators configured, and settings for analog and digital variables made (as of system version 5).

PLC parameters

If applicable, PLC parameters are defined here.

Programs

Programs (setpoint values, operating contacts) are created here using the program editor.

CODESYS configuration

The storage interval for CODESYS data can be activated here and the time interval set.

Recorder

The process values to be recorded are selected here and data recording configured. The signals of the connected sensors can be organized into groups. 10 groups are created as standard.

A maximum of 8 analog and 8 digital signals can be visualized per group. Additional signals can be saved in the group, but cannot be visualized as a live trend.

There are the following setting options for each group:

- Parameters
- Diagram view
- Analog channels
- Digital channels
- Standard operation
- Event operation
- Time operation

Recording data export

The connection to the database is configured and activated here (available as of system version 6).

Cloud gateway

The connection to the JUMO Cloud is configured here (available as of system version 4).

The tile must be activated under "App management".

Signal generator

Analog and digital signals within the system are specified here and various signal parameters set.

The tile must be activated under "App management".

Wtrans gateway

Settings for the use of JUMO Wtrans transmitters are made here (available as of system version 5).

Node-RED

Use of the Node-RED development tool is activated here.

The tile must be activated under "App management".

Batches

Batch logging is configured here (available as of system version 6).

UI resources

Icons, colors, fonts and font sizes are configured here.

App management

The "Signal generator", "Email", "Node-RED", "Cloud gateway" and "System bus" tiles are activated or deactivated here. The device must be restarted for the changes to take effect.

5 Operation

Service

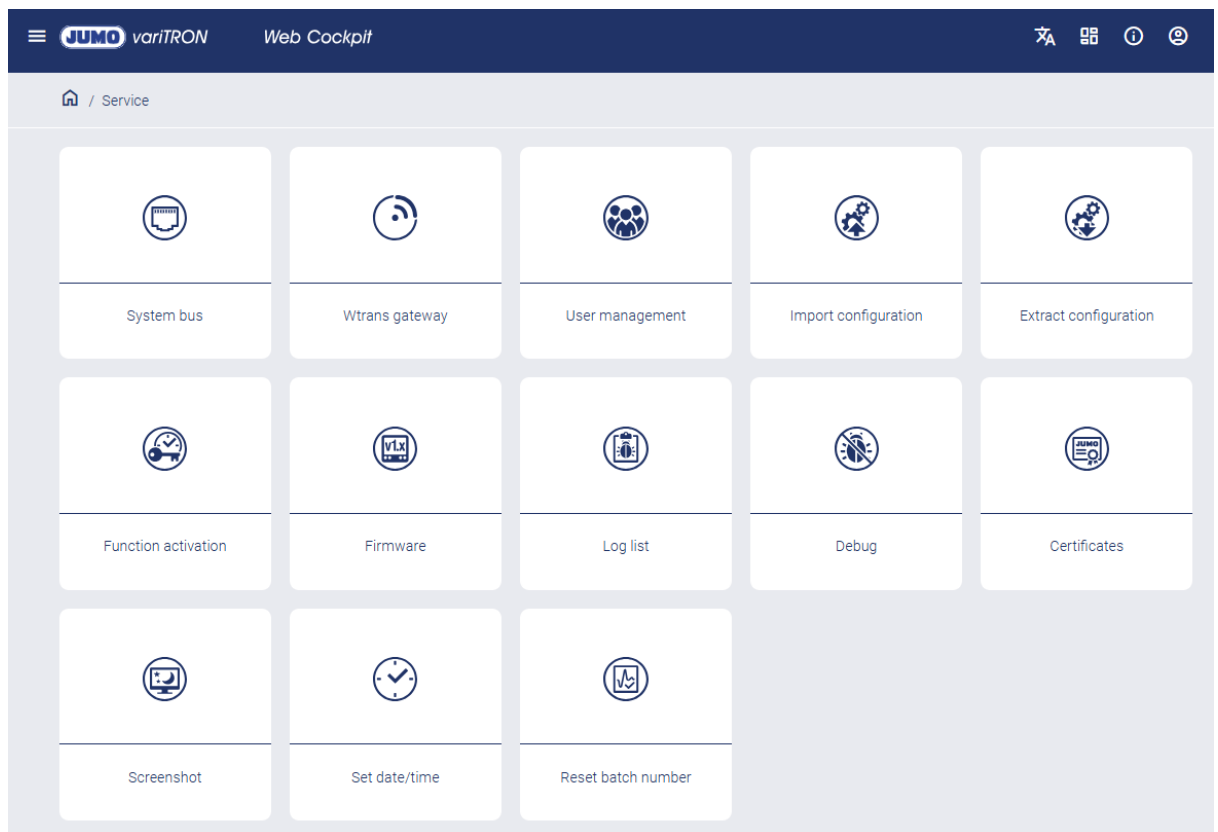

System bus

Information on the system bus master and the slaves is displayed here, for example:

- Actual and target status (system bus status)
- Device address and alias address
- Available ports (system bus interfaces)
- Hardware and software version
- Assignment of expansion slots

The following functions are available:

- Bus topology mode active (as of system version 5): Only for service purposes; displays the actual hardware configuration.
- Debug output active: Only for service purposes
- Reset: System bus restart
- Stop/Run: changeover of the system bus status (Safe-Operational/Operational; independent of system status)
- Reset statistics



CAUTION!

If bus topology mode is activated in the "Operational" system bus status, the system bus goes to the "Initialization" status.

The cyclical transmission of values is therefore interrupted.

- ▶ Only use this function for service purposes!

Wtrans gateway (only with JUMO variTRON 300 and JUMO variTRON 500 touch)

Information on the Wtrans transmitters is displayed here (e.g. status, transmitter ID, battery state, RSSI value).

User management

Users are created and assigned user rights here.

The user rights are defined in what are known as roles, which represent typical remits such as administrator or operator. Users are assigned rights by assigning them the relevant role. Users can also be assigned more than one role.

⇒ chapter 8.1 "User rights", Page 123

Import configuration

A configuration file (.jcf) is selected and transferred to the device here.

Once the configuration has been successfully transferred, the device restarts.

Extract configuration

The configuration is extracted from the device and saved as a configuration file (.jcf) here.

Function activation

Extra codes are activated here.

Extra codes are additional functions that are usually subject to a fee.



NOTE!

The files for activating extra codes (also called license files or FeatureResponse files) should be stored after they are first received so that they are available again for transmission to the device after a factory reset.

Firmware

The device's firmware is updated here.

For this purpose, switch the device to the status "Stop". Then select a firmware file (.raucb) and transfer it to the device. Afterward, create a new hardware configuration for the system (connected modules) using the setup program and transfer it to the device.

As an option, a configuration file (.jcf) can also be selected and transferred to the device here.

As of system version 8.2, there is also the option of adopting the current configuration (must be compatible with the firmware).

Log list

Log entries are extracted from the device and listed here.

The information shown can be filtered by entry type (information, warning, error, event, audit trail message, alarm, malfunction). It is also possible to run a full-text search.

Debug

Debug data is extracted from the device here.

The file containing the debug data (.jdf) can be saved locally on the PC and sent to the manufacturer for analysis purposes.

5 Operation

Use of a USB flash drive



NOTE!

It is also possible to update the firmware, import and extract the configuration (import, export), and extract the debug data using a USB flash drive.

⇒ chapter 5.2.2 "Device menu", Page 39

Certificates

Certificates can be added or replaced here

Device screenshot

Screenshots of the screen of the JUMO variTRON 500 touch can be made here. The graphic is provided in the download folder of the computer being used.

Set date/time

The date and time can be set here if NTP (⇒ "Time zone/NTP ", Page 86) is inactive. If NTP is active, time synchronization is carried out automatically and manually editing is not possible.

Reset batch number

The internal batch number can be reset here.

File explorer

Files and subfolders located in the Shared Folder are displayed here.

The files are available for download in the web browser (click on the file).

As of system version 8, the following functions are available (as buttons or in the context menu):

- Create new folder, rename, open, delete
- Download folder (as ZIP file)
- Upload, download, delete file(s)

In a CODESYS application, the shared folder can be accessed via the relative path **../ShareJumo**.

5.4.2 CODESYS WebVisu/Remote TargetVisu

The device supports CODESYS WebVisu or CODESYS Remote TargetVisu. By clicking the CODESYS WebVisu tile, visualizations created with CODESYS can be displayed in the browser of the connected PC/laptop and used to operate the system. For visualization by means of a browser, extra code 281 (WebVisu) is required; for visualization via CODESYS Remote TargetVisu, extra code 280 must be selected.

In principle, visualization can also take place on a JUMO web panel connected via Ethernet or a web panel that supports CODESYS visualization.

5.4.3 Other apps

The "Other apps" tile opens a browser window that you can use to access the JUMO Help Center. A QR code or a link is available for this.

The Help Center is an individual website on which JUMO provides further information on the following topics:

- JUMO Cloud
- JUMO smartWARE SCADA
- JUMO smartWARE Evaluation
- JUMO variTRON Program App
- JUMO variTRON

The information is continuously updated.

5 Operation

5.5 JUMO smartWARE Evaluation

JUMO smartWARE Evaluation is intended for evaluating and visualizing recorded process data from the JUMO variTRON system. The process data can be evaluated in customizable dashboards based on time or batch and transferred into reports (e.g. PDF, Excel®, CSV).

The figure shows a potential configuration and connection of multiple automation systems.

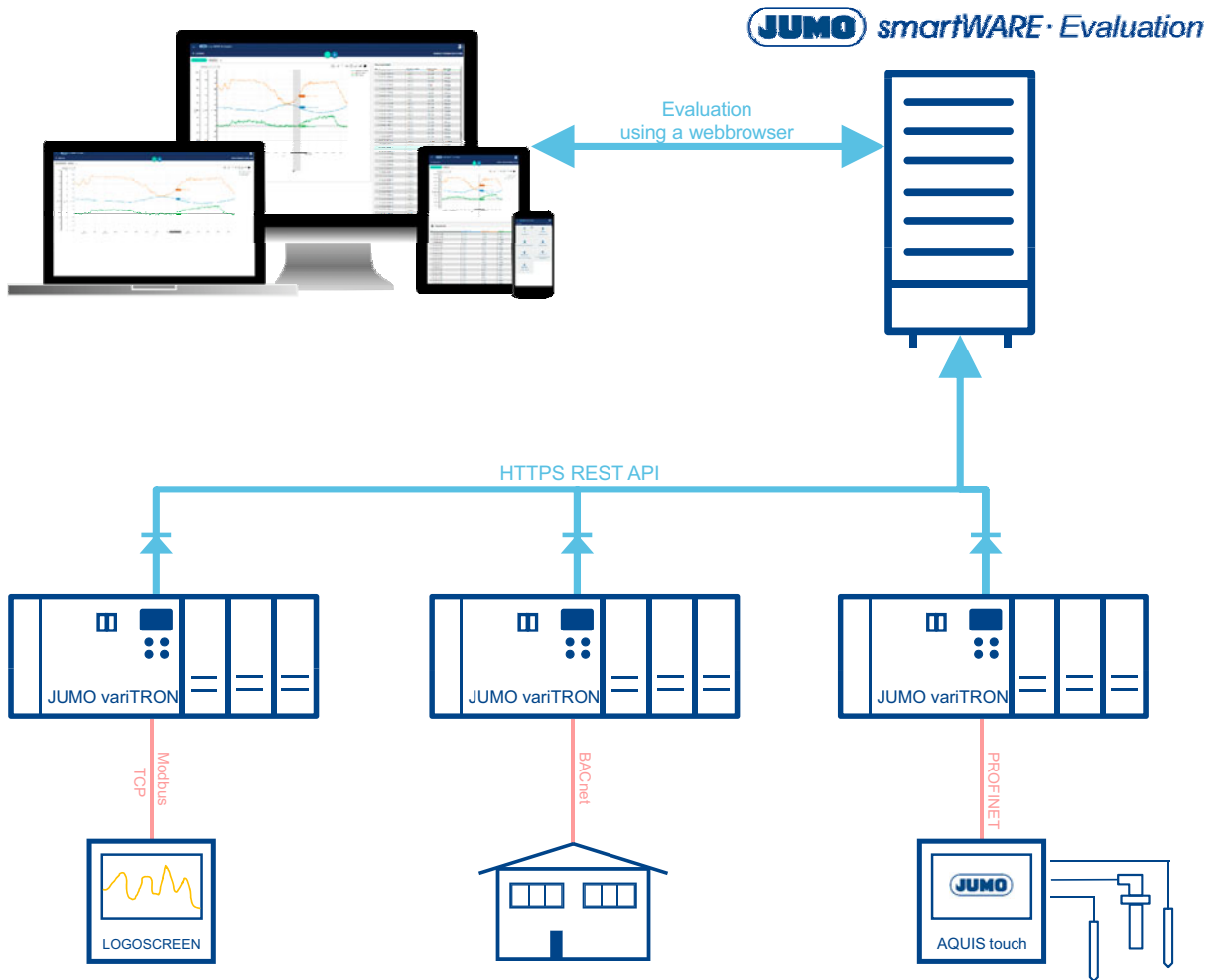

Details can be found on the data sheet 701840 available on the JUMO website.
JUMO smartWARE Evaluation is available at the following website:
<https://eval2.jumo.digital>

Do you need support?

If you need more information, simple explanations, training courses or support on the JUMO smartWARE Evaluation, there are a range of options available to you from JUMO.



JUMO Help Center
Detailed documentation

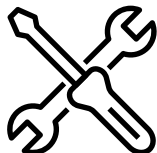

Technical Support
Questions and information



JUMO Engineering

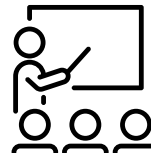

JUMO Campus
Training courses



YouTube channel
Explanatory videos

6.1 General information

As a basic principle, the device can be configured on the device itself, as well as using the setup program or the "Web Cockpit" web application. However, these configuration options differ in terms of the function areas that can be configured.

The following table provides an overview of which function areas are configurable by which means (= X).

Function area	Device with LCD display	Device with TFT screen	Setup program	Web application
Network	X	X	X	X
Device manager	X ^a	X ^a	X	X
Unit settings			X	X
System bus			X	X
Data carrier management			X	X
System status UI (LCD display, only with JUMO variTRON 300 and 500)	X		X	X
User interface (TFT screen, only with JUMO variTRON 500 touch)		X	X	X
Web server	X	X	X	X
Email			X	X
PLC configuration			X	X
PLC parameters ^b			X	X
Programs			X	X
CODESYS configuration			X	X
Recorder			X	
Recording data export			X	X
Cloud gateway			X	X
Signal generator			X	X
Wtrans gateway (only with JUMO variTRON 300 and variTRON 500 touch)			X	X
Node-RED			X	X
Batches			X	X

^a Several functions are not available.

^b PLC parameters can only be created in the setup under "PLC parameter definition" via CPVE.



NOTE!

The functions HW-Assistent (for defining the hardware configuration for the system), PLC application (for defining the start parameters and starting the programming system), and Languages (for defining the project language, and exporting and importing languages) are only available in the setup program.

Device with LCD display (JUMO variTRON 300, JUMO variTRON 500): If the configuration has been changed on the device, this change will not take effect until you confirm the query "Save settings" using the "Menu/OK" key.

6 Configuration

Device with TFT screen (JUMO variTRON 500 touch):

= Save settings

= Cancel without adopting changes

In the web application, selecting "Save" ensures the device applies a change that was made to the configuration. The change is not applied if you select "Exit".

In the setup program, the changed configuration must be transferred to the device in order for the change to take effect.

If applicable, the default settings are shown in **bold** in the following tables.

6.2 Network

6.2.1 Ethernet

LAN1

Parameter	Selection/data input	Description
Method		Method for assigning the IP address
	Manual	The IP address must be assigned manually.
	Automatic	The IP address is obtained from a DHCP server.
IP address	0.0.0.0 to 255.255.255.255	Manually assigned IP address The IP address may need to be requested from the administrator in question.
Subnet mask	0.0.0.0 to 255.255.255.255 (255.255.0.0)	Subnet mask if the IP address is manually assigned The structure of the subnet mask may need to be requested from the responsible administrator.
Standard gateway	0.0.0.0 to 255.255.255.255	IP address of the standard gateway (router) if the IP address is manually assigned The IP address of the standard gateway may need to be requested from the administrator in question.
DNS server IP		Obtain DNS server IP automatically
	Off (FALSE)	The IP address must be assigned manually (see below).
	On (TRUE)	The IP address is obtained automatically.
DNS server	0.0.0.0 to 255.255.255.255	Manually assigned IP address of the DNS server The IP address may need to be requested from the administrator in question.

LANx

Additional (optional) LAN interfaces may be provided depending on the device. The setting options are identical to those for LAN1.

6.2.2 Port configuration

Each of the LAN connections LAN1, LAN2, or LAN3 can be configured separately here.

Parameters	Selection/input	Description
Port management		Select how the relevant port (LANx, device-dependent) is to be used.
	No selection	No use type is set for the relevant port.
	PROFINET device	The relevant port is used as a PROFINET port.
	Ethernet/IP	The relevant port is used as an Ethernet/IP interface.

6 Configuration

6.3 Device manager

Device settings

Parameter	Selection/data input	Description
Device language	Select language	Language in which the texts are shown on the device display. Texts that do not have a translation in the selected language are displayed in English or German (or, if applicable, in the so-called developer language).
Start-up behavior		System status that is adopted by the device once it switches on:
	Run	"Run" system status
	Stop	"Stop" system status
	Last status	Last system status before the switch-off
Partition change after [x] start-up errors	5 to 50	After [x] errors during the boot process, the device boots from the secondary partition (backup partition). Afterwards there is a one-time possibility to boot from the primary partition again with REBOOT SYSTEM. If this fails, a software update is required. Possible errors during the boot process: <ul style="list-style-type: none">• Error in the device software• Interruption of the voltage supply

Device designations

Parameter	Selection/data input	Description
Device name	Enter text (or use existing text)	Designation of the device The device name is used in the web application, in the setup program, and, if applicable, in other PC programs. It can also be used by DeviceScan and the CODESYS application, for example for identification purposes.
DNS name	Enter text (or use existing text) The DNS name must not be used more than once in the network.	Name by which the device can be identified and addressed in the network. The name set per default is unique as it comprises the product group number and the MAC address.

Time zone/NTP

Parameter	Selection/data input	Description
Time zone	Select time zone	Time zone in which the device is operated.
NTP active		The device's time settings can be synchronized with a time server using the Network Time Protocol (NTP).
	Yes	Synchronization is active.
	No	Synchronization is not active.

Parameter	Selection/data input	Description
Server 1 Server 2 Server 3	Enter the address of the time server (or use an existing address) Example: de.pool.ntp.org	Up to three time servers can be entered. The server list is processed top down, in other words, the next time server on the list is only queried if the previous server is unreachable. It must be ensured that the server name is resolved to an IP address via a DNS server (see Configuration > Ethernet).
Maximum round-trip time	0 bis 99999 (5)	Maximum time in seconds between the client's request and the server's response (for local time server).

6.3.1 Customer-specific linearization

You can use the customer-specific linearization to create a customized linearization characteristic line for analog values. Two procedures are available for this: formulas or grid values (value pairs).

Temperature values must always be specified in °C. In general, use the measuring units without prefixes (e.g. A instead of mA).

Formula

Customer-specific linearization is specified using a polynomial. The polynomial is calculated for the entire linearization range.

Example (4th order polynomial): $y = X4 \cdot x^4 + X3 \cdot x^3 + X2 \cdot x^2 + X1 \cdot x + X0$

Parameter	Selection/data input	Description
Name	Enter text (or use existing text)	Designation of linearization
Measuring range start (Ymin)	-99999 to 99999 (0)	Start value of the y axis
Measuring range end (Ymax)	-99999 to 99999 (100)	End value of the y axis
Decimal places	0 to 6 (4)	Number of decimal places
Polynomial:		
X0	-99999 to 99999 (0)	Absolute component of the polynomial (point of intersection with the y axis)
X1	-99999 to 99999 (1)	Coefficient of the linear component (x)
X2	-99999 to 99999 (0)	Coefficient of the quadratic component (x ²)
X3	-99999 to 99999 (0)	Coefficient of the cubic component (x ³)
X4	-99999 to 99999 (0)	Coefficient of the quartic component (x ⁴)
...	-99999 to 99999 (0)	(max. up to 20th order)

Grid values

Customer-specific linearization is specified by entering up to 200 grid points (pairs of values X/Y). The value of X stands for the physical measured value (e.g., voltage in V, current in A, or resistance in ohm; depending on the sensor type) and the value of Y stands for the linearized value (e.g., temperature in °C).

6 Configuration

Parameter	Selection/data input	Description
Name	Enter text (or use existing text)	Designation of linearization
Decimal places	0 to 6 (4)	Number of decimal places
Grid values:		
Measured value (X)	-99999 to 99999 (0)	Value of the relevant grid point on the x axis
Linearized value (Y)	-99999 to 99999 (0)	Value of the relevant grid point on the y axis

6.3.2 Display

The colors for displaying alarm 1 and alarm 2 can be defined under "Display". Clicking on the field with the color symbol opens a pop-up window. You can either select the provided colors by clicking or by entering a hexadecimal code for the color to be displayed in the "HEX" field.

1. Navigate to the Configuration - Device manager - Display menu item.
2. Click on the button on the right next to the color symbol.
The "Color selection" pop-up window opens.
3. Click the color you want or, if known, enter the relevant hexadecimal code in the "HEX" field.
The point next to the field "HEX" displays the selected color and the relevant hexadecimal code.
4. Confirm the selection by clicking on "OK".
The color symbol in the button switches to the selected color.
5. Click the "Apply" button.
The display color has been changed

6.4 Unit settings

Units

These settings are relevant for the automatic conversion performed when the temperature unit is changed (°C/°F) (relates only to the PLC application).

Parameters	Selection/input	Description
Absolute temperature setting		Unit for temperature value
	°C	Degrees Celsius
	°F	Degrees Fahrenheit
	K	Kelvin
Relative temperature setting		Unit for temperature difference
	°C	Degrees Celsius
	°F	Degrees Fahrenheit
	K	Kelvin
Pressure setting	mbar	Millibar
	bar	bar
	N/m ²	Newton per square meter
	psi	Pound force per square inch
	Pa	Pascal
	hPa	
	kPa	Kilopascal
	MPa	Megapascal
Resistance setting	μΩ	Microohm
	mΩ	Milliohm
	Ω	Ohm
	kΩ	Kiloohm
	MΩ	Megaohm
Ratio	%	Percent
	‰	Per thousand
	ppm	Parts per million
Mixing ratio setting	g/kg	Gram per kilogram
	gr/lb	grains per pound grain = 0.0648 g pound = 453.59237 g (avoirdupois pound)
Absolute humidity setting	g/m³	g per cubic meter
	g/ft ³	g per cubic foot
Relative humidity setting	%rH	Percent relative humidity
Current setting	μA	Microampere
	mA	Milliampere
	A	Ampere
	kA	Kiloampere
Voltage setting	μV	Microvolt
	mV	Millivolt
	V	Volt
	kV	Kilovolt

6 Configuration

Parameters	Selection/input	Description
Time setting	μs	Microsecond
	ms	Millisecond
	s	Second
	min	Minute
	h	Hour
Memory size setting	B	Byte
	kB	Kilobyte
	MB	Megabyte
	GB	Gigabyte
Specific enthalpy setting	kJ/kg	Kilojoule per kilogram
	BTU/lb	British Thermal Unit per pound
Flow setting	m^3/s	Cubic meter per second
	l/s	Liters per second
	l/min	Liters per minute
	l/h	Liters per hour
	cm^3/s	Cubic centimeters per second
	m^3/h	Cubic meters per hour
	ft^3/min	Cubic feet (28.316 l) per minute
	ft^3/h	Cubic feet per second
	usgal/min	US gallons (3.785 l) per min
	usgal/h	US gallons per hour
	impgal/min	Imperial gallons (4.54609 l) per min
	impgal/h	Imperial gallons per hour
Volume setting	m^3	Cubic meter
	l	Liter
	cm^3	Cubic centimeter
	ft^3	Cubic foot
	usgal	US gallon
	impgal	Imperial gallon
Speed setting	m/s	Meters per second
	km/h	Kilometers per hour
	mph	Miles (1609.344 m) per hour
Conductivity setting	$\mu\text{S}/\text{cm}$	Microsiemens per centimeter
	mS/cm	Millisiemens per centimeter
	S/m	Siemens per meter
Frequency setting	Hz	Hertz
	kHz	Kilohertz
	MHz	Megahertz
	GHz	Gigahertz
	1/min	One per minute
	1/h	One per hour

6.5 System bus

Master

Parameters	Selection/input	Description
Max. repetitions	2 to 1000 (5)	Maximum number of times a faulty frame is repeated before the system bus switches to the status "Stop".
Continuation after system bus error		The device can continue automatically as soon as a system bus error that previously occurred is no longer present.
	Inactive	No continuation The device or the system bus must be manually switched back to the "Run" status. For example, the system bus can be separately switched to the status "Stop" (Safe-Operational) or "Run" (Operational) in the web application using the function "Service > System bus".
	Active	Continuation The device automatically switches back to the status "Run".
Ignore system start		The system bus status can be independent of the current system status (device status). This may be required if a CODESYS application first needs to perform extensive initialization before the system bus is permitted to switch to the "Run" status.
	Inactive	The system bus status follows the system status.
	Active	When the system starts, the system bus remains in the "Stop" status, regardless of the system status. The system bus must be separately switched to the "Run" status. This can be done in the CODESYS application (CmpSystembus), or performed manually in the web application (Service > System bus).
Task 1 cycle time	1000 to 1000000 µs (10000)	Read and write system bus cycle time for digital process values
Task 2 cycle time	10000 to 1000000 µs (100000)	Read system bus cycle time for analog process values
Task 3 cycle time	10000 to 1000000 µs (100000)	Write system bus cycle time for analog process values



NOTE!

The settings configured under "Master" influence the transfer of data via the system bus. Sub-optimal settings here will disrupt or even interrupt communication within the system. For this reason, these parameters are only permitted to be modified by a service engineer from the device manufacturer (or by someone acting on their instructions).

Modules

The process of configuring the modules (controllers, relays, analog IO units, digital IO units) is described in the operating manual for the respective module.

6 Configuration

⇒ chapter 1.8 "Available technical documentation", Page 15

If used together with a type JUMO variTRON CPU, the description of the NV connecting list provided in the manual does not apply. In this case, all external connections (connections running via the system bus) must be realized in the PLC application.

6.6 Data carrier management

Network drives

Here up to 5 network drives are mounted under Linux (available as of system version 7).

Parameter	Selection/data input	Description
Name	Enter text (only ASCII characters)	Designation for the network drive Examples: Drive1, Drive2
Network path	Enter text (only ASCII characters)	Network path of the drive Examples: //Server/NetDrive, //Server/NetDrive2
File system	SMB/CIFS	Network file system SMB/CIFS is supported up to and including version 3.1.1. To use a specific version, it must be specified as an additional mount option (vers=x.x).
Log on as guest (as of system version 8)	Off (FALSE) On (TRUE)	Username and password are required for logon. Logon without user name and password
User name (as of system version 8)	Enter text	User name for access to the network drive
Password (as of system version 8)	Enter text	Password for access to the network drive
Additional mount options	Enter text	Additional options for mounting the drive under Linux The options are to be entered separated by commas. Example (public drive, SMB/CIFS in version 1.0): guest,user=,vers=1.0



NOTE!

As of system version 7, access to the file system on USB storage media via CODESYS is also supported.

6 Configuration

6.7 System status UI

This function area relates to the configuration of the device display.

Screensaver

Parameter	Selection/data input	Description
Function		Activate screen switch-off
	Off	The function is inactive.
	On	The screen is switched off once the waiting period has elapsed.
Waiting period (s) (idle time)	10 to 3600 (900)	Waiting period in seconds

6.8 Web server

Parameters	Selection/input	Description
HTTP		The web server can always be reached via HTTPS; HTTP can be activated in addition.
	Active	HTTP is active in addition to HTTPS.
	Inactive	HTTP is not active.
	Redirect to HTTPS	HTTP is active, but there is an immediate redirect to HTTPS.
HTTP port number	0 to 65535 (80)	Port number for HTTP
HTTPS port number	0 to 65535 (443)	Port number for HTTPS
Path to user-defined website	custom	Link is specified when using a user-specific website
CODESYS WebVisu compatibility		Move slider to the right to activate compatibility mode

6.9 Email

Parameter	Selection/data input	Description
SMTP server	Enter address (smtp.example.de)	Address (URL) of the email server for SMTP
Port	0 to 65535 (25)	Port number of the email server for SMTP The port number is dependent on the email provider and the type of encryption (usually: TLS = 465, StartTLS = 587).
User account	Enter designation (user@example.de)	Designation of the user account (user name) for logging on to the email server
Authentication		Authentication at logon to email server
	None	No authentication
	Password	Authentication using password
Password	Enter password	Password for authentication
Encryption		Type of encryption between email client and email server (depending on the email provider)
	None	Unencrypted transfer
	StartTLS	TLS where the connection is unencrypted to begin with (encryption takes place while the connection is being established)
	SSL/TLS	Transport Layer Security
Check certificates		Check SSL/TLS certificates
	No	No check
	Yes	Certificates are checked.
Sender	Enter designation (device@example.de)	Email address as sender address

6 Configuration

6.10 PLC configuration

6.10.1 Program generator

Nine independent program generators are available in the device as standard, meaning that nine programs can run asynchronously and independently from each other.

With the extra code 001, the program generator is supplemented with the JUMO variTRON Program App. The operating manual for the JUMO variTRON Program App is available online in the JUMO Help Center.

General information

Parameters	Selection/input	Description
Name of program generator	Enter text (or use existing text)	Designation of program generator
Function	Inactive	The program generator is switched off.
	Program generator	The program generator is controlled by a program.
	Fixed-setpoint generator	The program generator operates as a fixed-setpoint generator. In this case, the setpoint values for the basic status or manual mode are used.
Program start	Program start	The program starts at the first programmed setpoint value.
	Actual value	The program starts at the point at which the setpoint value corresponds to the current actual value.
	Time	A start time specified for program start is adopted as the start time in a 24 h program. Example: Start time: 06:00:00; 24 h program from 00:00 to 24:00: The program starts at 6 a.m. and runs until midnight.
Response at out of range (O-o-R)		Behavior of the program generator in case of measuring range underflow and overflow (out of range)
	Continuation	Program continues to run.
	Program stop	The program is stopped.

6 Configuration

Parameters	Selection/input	Description
Power off		Behavior of the program generator when the power failure is over.
	Cancellation	The program is aborted; the program generator enters basic status.
	Continuation	The program continues running from the point that it was at when the power failed.
	Standstill	The program is stopped (program generator stays in automatic mode). The program can be continued or canceled by means of operation.
	Continuation at x %	If the difference in the actual value (before and after the power failure) is less than or equal to x %, the program continues running from the point that it was at when the power failed. If this is not the case, the program generator enters standstill.
	Continuation at actual value	The program continues running at the actual value; consideration is given to whether the program profile had a positive or negative slope at the time of the power failure.
Start with time		The program can be started at a specific time (entry of date and time by means of operation).
	No	Immediate program start (e.g., by means of operation or digital signal)
	Yes	Program start at a specific time
Actual value difference	0 to 100	The maximum admissible difference between the actual value before and after the power failure for the program to continue running.
End signal (s)	0 to 32767	Length of the program end signal
Events (Program start, ...)		Activate the event message for the relevant event.
	Off (FALSE)	No event message
	On (TRUE)	The event is entered in the event list.
Event text	Enter text (or use existing text)	This text is entered in the event list in the case of an event.

Setting of setpoint values: setpoint specification

Parameters	Selection/input	Description
Setpoint value 01 to setpoint value 30		Specification of whether a change made to the setpoint value should take the form of a step or a ramp.
	Setpoint value step	Setpoint value change as step
	Setpoint value ramp	Setpoint value change as ramp
	End value for setpoint value ramp 1 to End value for setpoint value ramp 10	The relevant setpoint value acts as the end value for the ramp function of the setpoint value (1 to 10) which is selected here. If there is no end value specified in a program section, then the program generator works in accordance with its configuration (setpoint step or setpoint ramp).

6 Configuration

Setting of setpoint values: setpoint limits

Parameters	Selection/input	Description
Decimal places	Auto	The number of decimal places is selected automatically.
	XXXXXp	No decimal place
	XXXXpX	One decimal place
	XXXpXX	Two decimal places
	XXpXXX	Three decimal places
	XpXXXX	Four decimal places
Lower tolerance band limit		
Minimum	-99999 to 99999	Admissible minimum value for the lower tolerance band limit
Maximum	-99999 to 99999	Admissible maximum value for the lower tolerance band limit
Upper tolerance band limit		
Minimum	-99999 to 99999	Admissible minimum value for the upper tolerance band limit
Maximum	-99999 to 99999	Admissible maximum value for the upper tolerance band limit
Setpoint value 01 to setpoint value 30		
Designation	Enter text (or use existing text)	Designation of the setpoint value
Minimum	-99999 to 99999	Admissible minimum setpoint value
Maximum	-99999 to 99999	Admissible maximum setpoint value

Setting of setpoint values: setpoint values for manual mode

Parameters	Selection/input	Description
Lower tolerance value	-99999 to 99999	Lower value of the tolerance band
Upper tolerance value	-99999 to 99999	Upper value of the tolerance band
Setpoint value 01 to setpoint value 30	-99999 to 99999 (0)	Value of the setpoint value concerned
Contact 01 to contact 32		Position of the operating contact concerned
	Off (FALSE)	Contact not active
	On (TRUE)	Contact active

Setting of setpoint values: setpoint values for basic status

Parameters	Selection/input	Description
Lower tolerance value	-99999 to 99999	Lower value of the tolerance band
Upper tolerance value	-99999 to 99999	Upper value of the tolerance band

6 Configuration

Parameters	Selection/input	Description
Setpoint value 01 to setpoint value 30	-99999 to 99999 (0)	Value of the setpoint value concerned
Contact 01 to contact 32		Position of the operating contact concerned
	Off (FALSE)	Contact not active
	On (TRUE)	Contact active

Setting of setpoint values: setpoint value units

Parameters	Selection/input	Description
Setpoint value 01 unit to setpoint value 30 unit		Unit of the setpoint value concerned
	No unit	
	Absolute temperature	Temperature value
	Relative temperature	Temperature difference
	Relative humidity	Relative humidity
	Ratio	Ratio of two values A and B (A / B) in percent
	Hours	Hours
	Minutes	Minutes
Seconds	Seconds	

Names of operating contacts

Parameters	Selection/input	Description
Name of operating contact 01 to Name of operating contact 32	Enter text (or use existing text)	Designation of the operating contact concerned

Tolerance band monitoring

Parameters	Selection/input	Description
Alarm type	Inactive	Tolerance band monitoring is not active.
	Event	The tolerance band breach is entered as an event in the event list.
	Alarm	The tolerance band breach is entered as an alarm in the event list and alarm list.
Alarm active at	High	Alarm active at High (1 = actual value outside the tolerance band)
	Low	Alarm active at Low (0 = actual value within the tolerance band)
Event text	Enter text (or use existing text)	This text is entered in the relevant list in the event of the tolerance band breach.
Stop if tolerance range exceeded		In the event of a tolerance band breach, the program can be stopped until the state has passed.
	Yes	The program is stopped.
	No	The program is not stopped.

6 Configuration

6.10.2 Analog variables

These settings concern the use of analog variables (analog PLC outputs) for functions that have been realized in the device firmware (e.g. data recording). 120 analog variables for customization are available.

Parameters	Selection/input	Description
Name	Enter text (or use existing text)	Designation of the variables concerned
Unit	Select signal type and unit from the list (drop-down menu)	Signal type and unit of the variables concerned
Display start	-99999 to 99999 (0)	Lower limit of display range
Display end	-99999 to 99999 (100)	Upper limit of display range

6.10.3 Digital variables

These settings concern the use of digital variables (digital PLC outputs) for functions that have been realized in the device firmware (e.g. data recording). 120 digital variables for customization are available.

Parameters	Selection/input	Description
Name	Enter text (or use existing text)	Designation of the variables concerned

6.11 PLC parameters

The configuration structures that were individually created using the CPV Editor (CPVE) are displayed here.

This configuration data can be used in the setup program, in the web application, and in the CODESYS application.



NOTE!

The CPV Editor requires specific knowledge and is intended for use by the manufacturer only (service that is subject to a fee).

6.12 Programs

Each program (each program plan) can consist of a maximum of 200 program sections. Up to 30 setpoint values and up to 32 operating contacts can be used in each program section.

Tolerance band monitoring can be set up for the first setpoint value. This means that the relevant actual value is monitored; if it leaves the tolerance band, the program is stopped until it returns to a value that is within the tolerance band (depending on configuration).

A total of up to 300 programs can be managed in a program pool.

A program generator is required to execute a program. A program can also be assigned multiple program generators.

Program header

Parameter	Selection/data input	Description
Program GUID	Enter ID (0)	ID for uniquely identifying the program (length: 64 bits)
Program name	Enter text (or use existing text)	Designation of the program
Program information	Enter text (or use existing text)	Description of the program
Pictogram name	Select pictogram	Pictogram (icon) for graphical identification marking of the program
Favorite		Programs marked as favorites are placed at the start of the program start menu. If there is more than one favorite, the program number is the decisive criterion (in ascending order).
	No	Program is not a favorite
	Yes	Program is a favorite
Repetitions		Cyclic program repetition
	Inactive	The program is not repeated (only one program run).
	Endless	The program is repeated endlessly.
	Number	The program is repeated as many times as is specified by the parameter "Number of repetitions".
Program assignment (allocation)	-9223372036854775808 to 9223372036854775807 (0)	Number (length: 64 bits) for assigning a program to a plant or a group. This number can be used in the customer-specific application to group similar programs.
Number of repetitions	0 to 99999	Number of program repetitions
Assignment (allocation)		Selection of program generators to be used to execute the program.
	Off (FALSE)	Program generator not selected
	On (TRUE)	Program generator selected

6 Configuration

Program channel

Parameter	Selection/data input	Description
Number of sections	0 to 200	Number of program sections that the program generator is to process.
Program section 1 to Program section 200		
Process step (procedural step) (available as of system version x)	0 to 200	The process step specifies the limits of the section time and defines which setpoint values are available.
Section time (hh:mm:ss)	00:00:00 to 99:59:59	Duration of program section As from system version x: The section time must be within the limits specified by the process step.
RS (Repeat section) Start section	1 to 200	Number of the program section that is to be repeated together with the following sections.
NoC (Number of cycles) Number of cycles	0 to 999	Number of repetitions of a program section (or multiple linked program sections)
Setpoint value 01 to Setpoint value 30	-1000000 to 1000000 The limits depend on the admissible minimum and maximum setpoint values of the program generator.	Setpoint values in the program section As from system version x: Only the setpoint values approved in the process step can be used.
Tol high	-1000000 to 1000000 (0) The limits depend on the admissible minimum and maximum upper limit of the tolerance band for the program generator.	Upper limit value for tolerance band monitoring of setpoint value 01
Tol low	-1000000 to 1000000 (0) The limits depend on the admissible minimum and maximum lower limit of the tolerance band for the program generator.	Lower limit value for tolerance band monitoring of setpoint value 01
Operating contact 01 to 32		Operating contacts in the program section
	Off (FALSE)	Operating contact is not active.
	On (TRUE)	Operating contact is active.

6.13 CODESYS configuration

Parameters	Selection/input	Description
RetainAutoSync	Active	Retain data is automatically synchronized in the retain memory in the storage interval ^a .
	Inactive	No retain data is synchronized ^b .
Storage interval	1 to 86400 s (5)	CODESYS configuration storage interval

^a If the retain data is to be synchronized in the retain memory (backup through power off) outside the storage interval, this can be carried out through access via the CODESYS component.

^b The user is responsible for the synchronization. This can be carried out through access via the CODESYS component. If no synchronization takes place, this can result in loss of the retain data.

6 Configuration

6.14 Recorder

The JUMO variTRON system has an integrated recorder, which records process data. The Recorder View is available using the extra code 276 "Recorder App". It enables process data from the JUMO variTRON system to be visualized as a live trend in a curve diagram. The recorded process data is archived and evaluated with JUMO smartWARE Evaluation ⇒ [Data sheet 701840](#).



NOTE!

In addition to archiving and evaluating process data with JUMO smartWARE Evaluation, it is possible to transmit the data to the JUMO Cloud or to JUMO smartWARE SCADA.

Groups

The process data is stored in so-called groups. The device has a total of 10 groups. In each group, up to 8 analog and 8 digital signals can be displayed as a live trend in the curve diagram (prerequisite: extra code 276 is activated).

Overall, the JUMO variTRON 300 can record up to 60 analog or digital signals. The JUMO variTRON 500 and JUMO variTRON 500 touch can record up to 240 analog or digital signals. The signals can be divided across the groups as desired.



NOTE!

The user must ensure that the maximum number of channels is not exceeded (60 or 240). The sum of analog and digital channels of all groups is decisive for this.

If the maximum number of channels is exceeded during the configuration of a group, this results in the complete group not being recorded. In the event of configuration with the Web Cockpit, an error message is entered directly in the event list.



NOTE!

In order to transmit the saved process data to JUMO smartWARE Evaluation for archiving or evaluation, the recording data export must be configured.

Parameters

Parameters	Selection/input	Description
Name	Enter text	Designation of the group The designation is displayed in the visualization (Recorder View and JUMO smartWARE Evaluation).
Recording (as of system version 8)	Normal	Amount of data saved in a memory cycle Not only the measured value, but also metadata such as minimum value, maximum value, average value (avg.), validity (Valid/Invalid), measuring range underflows (Under), and measuring range overflows (Over) are saved.
	Compact	Only the current value is saved. This saves on memory capacity in both JUMO variTRON and JUMO smartWARE Evaluation.

Diagram view

Parameters	Selection/input	Description
Measured value display	Min. value	The minimum value is displayed.
	Max. value	The maximum value is displayed.
	Current value	The current value is displayed.
	Mean value	The mean value is displayed.
Alignment	Horizontal	Horizontal alignment of the diagram.
	Vertical	Vertical alignment of the diagram.

Analog channels

The display of the analog signals in the curve diagram of the Recorder View is set here (e.g. channel color).



NOTE!

A key symbol after an entry indicates that the entry is blocked for input. The entry can be edited if a valid analog signal is configured at the input using a selector.

Parameters	Selection/input	Description
Input signal	Select signal from selector	Analog signal System version 5: Analog PLC outputs (analog values 001 to 120) As of system version 6: Additional analog signals available (values of system monitoring, process values of the modules).
Designation	Enter text (or use existing text)	Designation of the signal
Replace designation	Inactive Active	If active: The channel designation is automatically displayed in JUMO smartWARE Evaluation.
Start of display range	-99999 to 99999 (0)	Lower limit of display range
End of display range	-99999 to 99999 (100)	Upper limit of display range
Replace display parameters	Inactive Active	If active: The display parameters are automatically used in JUMO smartWARE Evaluation.
Scaling type		Scaling of the y axis
	Linear	Linear
	Logarithmic	Logarithmic
Channel color		Any color can be set by selecting a color or entering a hexadecimal value.
Setting the number format for the analog value		
Decimal place	Auto	The system sets the number format automatically
	XXXXXp	Display of the value without decimal place
	XXXXpX	Display of the value with a decimal place
	XXXpXX	Display of the value with two decimal places
	XXpXXX	Display of the value with three decimal places
	XpXXXX	Display of the value with four decimal places

6 Configuration

Parameters	Selection/input	Description
Number format	Decimal	Display as decimal value
	Exponential	Display as exponential value
Recorder View	Active	If "Active", the analog signals are displayed as a live trend in the curve diagram. A maximum of 8 analog signals and 8 digital signals can be displayed per group. If there are 10 groups, a total of up to 80 analog signals and 80 digital signals are therefore possible.

Digital channels

The display of the digital signals in the curve diagram of the Recorder View is set here (e.g. channel color).

Parameters	Selection/input	Description
Input signal	Select signal from selector	Setting of the digital input signal
Designation	Enter text or use existing text	Designation of the signal
Replace designation	Inactive Active	If active: The channel designation is automatically displayed in JUMO smartWARE Evaluation.
Channel color		Any color can be set by entering a hexadecimal value.
Recorder View	Active	If "Active", the analog signals are displayed as a live trend in the curve diagram. A maximum of 8 analog signals and 8 digital signals can be displayed per group. If there are 10 groups, a total of up to 80 analog signals and 80 digital signals are therefore possible.

Standard operation

Storage operation is switched on/off for the group and the memory cycle set here.

Parameters	Selection/input	Description
Memory status		Activation of data recording
	On	The data is recorded at the configured interval.
	Off	Data recording is not active.
Memory cycle [hh:mm:ss]	00:00:01 to 24:00:00 (00:00:05)	Recording interval Time interval at which the values of the analog and digital signals of the group are stored for evaluation.

Event operation

Settings for event operation are configured here.

Event operation has the highest priority of all three operating modes.

Parameters	Selection/input	Description
Control signal	Select signal from selector	Digital signal (binary signal) that starts and stops event operation.
Post-trigger time [s]	0 to 10 (0)	Extends event operation after which the control signal was deactivated.
Memory cycle [hh:mm:ss]	00:00:01 to 24:00:00 (00:00:01)	Recording interval Time interval at which the values of the analog and digital signals of the group are stored for evaluation.

Time operation

A period of time in which the data recording is to take place can be set here.

Time operation has higher priority compared with standard operation, but lower priority than event operation.

Parameters	Selection/input	Description
Begin [hh:mm:ss]	00:00:00 to 23:59:59 (00:00:00)	Time at which time operation is started. Begin = End: Time operation is inactive.
End [hh:mm:ss]	00:00:00 to 23:59:59 (00:00:00)	Time at which time operation ends.
Memory cycle [hh:mm:ss]	00:00:01 to 24:00:00 (00:00:01)	Recording interval Time interval at which the values of the analog and digital signals of the group are stored for evaluation.

Recorded values

The following values are determined within a recording interval:

- Current value (current value at the end of the interval)
- Measured value status (status of the current value according to NAMUR NE107)
- Minimum value (for digital signal: number of low values (logical 0))
- Maximum value (for digital signal: number of high values (logical 1))
- Average value (for digital signal: number of high values in relation to the number of low values)
- Number of values with measuring range underflow
- Number of values with measuring range overflow
- Number of valid values
- Number of invalid values

6 Configuration

6.15 Recording data export

Recording data export

Here the connection to the JUMO smartWARE Evaluation (Datastore) is configured and activated (available as of system version 6). In the Datastore, the recorded process data is stored. The data is then available for evaluation with JUMO smartWARE Evaluation (as of system version 6).

Parameters	Selection/input	Description
Data export		Export of the recorded process data
	Inactive	The function is switched off.
	Active	The function is active. Activates the data export function, meaning data can be exported via USB or http/https.
Export to data server		Activates the automatic export of data via http to the Datastore at the set interval (period).
	Active	
	Inactive	
Datastore URL	Enter the URL of the Datastore of JUMO smartWARE Evaluation (<host>/store)	The URL is usually entered as follows: (host/store) Example: 10.12.54.18/store or eval2.jumo/store Depending on the port configuration of JUMO smartWARE Evaluation, it must also be specified too. If the ports of JUMO smartWARE Evaluation are configured differently to 80/443, <Hostname>:<Port>/store<IP address>:<Port>/store must be entered. For further information ⇒ Operating manual for JUMO smartWARE Evaluation .
Encryption		A setting can be made to determine whether the data is sent to the Datastore via http (unencrypted) or via https (TLS encryption). Depending on this, it may be necessary to enter the correct port in the Datastore.
	No	No data encryption occurs
	SSL/TLS	SSL/TLS encryption (https)
API key		An API key can optionally be defined in the Datastore that restricts data export to devices which also use it. This API key must be entered in the device here if the relevant Datastore defines one.
Period [hh:mm:ss]	00:01:00 to 24:00:00 (00:15:00)	Interval at which the recorded data is transferred to the Datastore.
Memory alarm limit value	0 to 100 % (20 %)	Warning threshold for the remaining database storage capacity for process data. When it is reached, an alarm is generated.

6.16 Cloud gateway

Here the connection to the JUMO Cloud is configured (available as of system version 4). Before this, the device must be configured as a data source in the JUMO Cloud.

As of system version 8, the connection to a SCADA system is also configured here.

Parameter	Selection/data input	Description
Connection to cloud or SCADA		Activation of the cloud gateway
	Inactive	Gateway is not active.
	Active	Gateway is activated.
Target server		Selection of the destination server
	JUMO Cloud	The JUMO Cloud is used.
	SCADA (individual)	The destination server is determined by an individual URL (JUMO smartWARE SCADA, compatible third-party systems).
SCADA URL for configuration	Enter URL	Individual URL for connecting to a SCADA system (configuration)
SCADA URL for MQTT	Enter URL	Individual URL for connecting to a SCADA system (MQTT broker)
Ignoring server certificate	Inactive	In the case of HTTPS connections, this parameter must be set to active, as otherwise no connection will be established. Only HTTPS connections to JUMO Cloud are possible.
	Active	
Device ID	Enter device ID	ID used by the device (data source) to authenticate itself to the JUMO Cloud or the SCADA system. The ID is generated in the JUMO Cloud or in the SCADA system and must be entered here.
Password	Enter password	Password used by the device (data source) to authenticate itself to the JUMO Cloud or the SCADA system. The password is generated in the JUMO Cloud or in the SCADA system and must be entered here.

6 Configuration

6.17 Signal generator

Analog and digital signals within the system are specified here and various signal parameters set.

Analog signals

Parameters	Selection/input	Description
Signal type	No signal	–
	Sine	Curve form
	Cosine	
	Triangle signal	
	Rectangle	
	Saw tooth	
	Fixed value	
	Exponential	
Phase delay	-99999 to 99999 (0)	The signal path is shifted along the time axis so that it starts earlier or later.
Amplitude	0 to 99999 (1)	Maximum signal deflection
Rest position	-99999 to 99999 (0)	Base value around which the signal type oscillates
Period [hh:mm:ss]	00:00:01 to 00:16:39 (0:00:05)	Duration of a complete signal cycle
Unit	Select unit from selector	Unit for analog signal X

Digital signals

Parameters	Selection/input	Description
Signal type	No signal	–
	Periodically	Signal path
	Random	
	Fixed value	Curve form
Period [hh:mm:ss]	00:00:01 to 00:16:39 (0:00:05)	Duration of a complete signal cycle
Start value	Off (FALSE)	Start value is not active
	On (TRUE)	Start value is active

6.18 Wtrans gateway

Settings for using the JUMO Wtrans transmitters are made here (available as of system version 5).

General

Parameter	Selection/data input	Description
Radio frequency		Wtrans radio frequency (MHz)
	868.4	Europe
	912.6 to 917.4	America, Australia, Canada and New Zealand

Wtrans transmitter

These settings are required for each transmitter selected in the Wtrans hardware configuration (Wtrans hardware assistant in the Setup program).

Parameter	Selection/data input	Description
General		
Name	Enter text (or use existing text)	Transmitter designation
Transmitter ID	0 to 99999	ID of the Wtrans transmitter The unique ID set on the transmitter side must also be set here to identify the transmitter.
Radio timeout	2 to 20	Number of radio telegrams not received, which leads to timeout detection. The set transmission interval of the transmitter is transmitted with the radio telegram. When the first telegram is received, this value is saved in the receiver and the radio timeout monitoring function is activated. If no new telegram is received throughout the entire timeout period, the measured value is set to "no input value" and the "Radio timeout" alarm is activated.
Analog processing		
Name (for Wtrans E01; as of system version 6)	Enter text (or use existing text)	Designation of measured value
Factor	-99999 to 99999 (1)	Factor for correction of the measured value
Offset	-99999 to 99999 (0)	Offset value for correction of the measured value
Linearization	Select linearization from selector (customer-specific linearization: formula or grid points)	Linearization for the measured value Configuration of linearization: Configuration > Device manager > Customer-specific linearization

NOTE!



Wtrans B (707060) with thermocouple: With system version 5, only types J, K, and B are supported. With system version 6, all types except MoRe5-MoRe41 and W3Re-W26Re are supported.

6 Configuration

6.19 Node-RED

The graphical development tool Node-RED is available as standard, but has to be activated before it is used.

Parameters	Selection/input	Description
Node-RED development tool		Activation of Node-RED in the central processing unit
	Inactive	Node-RED is not active.
	Active	Node-RED is active and can be used with a web browser. The IP address of the central processing unit and /nodered have to be entered to start Node-RED: http://<IP address>/nodered



NOTE!

If Node-RED is active, the tile Node-RED is shown on the device homepage (IP address) once Node-RED has completely started.

6.20 Batches

Batch logging is configured here (available as of system version 6).

The batch data is displayed together with the channels of the assigned groups and the event messages in the batch visualizations (evaluation with JUMO smartWARE Evaluation).

The maximum number of batches that can be configured depends on the device (JUMO variTRON 300: 10 batches; JUMO variTRON 500 and JUMO variTRON 500 touch: 20 batches). However, the number of licensed batches is what matters for the evaluation of recorded batches (licenses subject to charges for JUMO smartWare Evaluation).



NOTE!

If no group has been assigned to the batch (or none of the assigned groups is active), only event messages are recorded.



NOTE!

For the JUMO variTRON 300, the user must ensure that the maximum number of 10 batches is not exceeded.

If the maximum number of batches is exceeded during the configuration, this results in the batch in question not being recorded. In the event of configuration with the Web Cockpit, an error message is entered directly in the event list.



NOTE!

The configuration must not be amended if batch reporting is active. Otherwise, there is a danger of the batch documentation being rendered unusable.

The internal batch number can be reset, ⇒ Seite 80.

6.20.1 Batches

General information

Parameters	Selection/input	Description
Batch active	Off (FALSE)	Batch reporting is not active.
	On (TRUE)	Batch reporting is active and can be started.
Batch application (batch name)	Enter text (or use existing text)	Assignment or designation of the batch
Control signal	Select signal from selector	Signal that is used to start (High active) and stop batch reporting.
Behavior after power interruption	Continuation	Batch reporting is continued.
	Cancellation	Batch reporting is stopped. The batch is completed with the last recorded data (before the power failure).
Group assignment	Select group from selector	Group that is assigned to the batch. All groups can be assigned to one batch.

6 Configuration

Batch lines

For each batch, up to 10 lines can be defined for the batch report.

Parameters	Selection/input	Description
ID	Enter text (or use existing text)	Designation (ID) of the relevant line of the batch report (e.g. for use in the PLC application) The identifier must be unique within a batch.
Text left column	Enter text (or use existing text)	Text in the left column of the batch report. The left column contains the designation for the contents of the right column.
Contents of right column		Text or text source for the right line of the batch report
	Empty	No text
	Default text	Text from the "Default text" parameter
	Text selection	Text from the "Text list" parameter
Delete line	Text selection can be edited	
		The parameter decides whether a text edited during batch reporting is replaced again by the text specified in the configuration after the batch has been completed.
	Off (FALSE)	Text changes are retained.
	On (TRUE)	The original text (default text) is used for the next batch reporting.
Default text	Enter text (or use existing text)	The text is used in the batch report if the text in the right column is composed of "Default text", "Text selection" or "Text selection can be edited".
Editable		This parameter enables editing of the text within the current batch report.
	Off (FALSE)	The text in the right column can only be edited by changing the "Default text".
	On (TRUE)	The text in the right column can be changed - for the current batch report. Depending on the "Delete line" parameter, the configured text can be automatically reactivated after the batch is completed.
Text list	Select text list from selector	The selected text list is used in the batch report if the text in the right column is composed of "Text selection" or "Text selection can be edited".
Regular expression	Enter text	Designation of regular expression The batch cannot be started if it contains a line that does not match the specified regular expression.

6.20.2 Text lists

General information

Parameters	Selection/input	Description
Name	Enter text (or use existing text)	Designation of the text list

Texts

Parameters	Selection/input	Description
Entries	Enter text	Designation of the text

6.21 UI resources

Up to 20 colors are selected here.

6.22 App management

Services can be activated or deactivated here.

Any services not needed should be deactivated to relieve strain on system resources such as CPU load and working memory. Deactivated services are not displayed in the menu.

The device must be restarted for the changes to take effect.

Parameters	Selection/input	Description
Signal generator	Off (FALSE)	Signal generator not active
	On (TRUE)	Signal generator active
Email	Off (FALSE)	Email not active
	On (TRUE)	Email active
Node-RED	Off (FALSE)	Node-RED not active
	On (TRUE)	Node-RED active
Cloud gateway	Off (FALSE)	Cloud gateway not active
	On (TRUE)	Cloud gateway active
System bus	Off (FALSE)	System bus not active
	On (TRUE)	System bus active

7 Startup

By means of a summary list, this chapter describes the basic procedure to be followed when initially starting up the automation system. This list is intended to enable experienced users to get started quickly.

Requirements

- The work required to mount the entire system – comprising the CPU (also referred to as the "device" here) and the connected modules – and establish its electrical connections is complete (incl. establishing the network connection via the Ethernet interface).
- The network includes a DHCP server from which the CPU obtains its IP address (otherwise this address must be assigned manually; see "Configuration > Ethernet").
- The setup program (basic software and variTRON plugin) has been installed and started on a PC that is also connected to the network.

Process

1. Connect central processing unit via LAN1 with the system bus.
2. Establish voltage supply.
The boot process starts and ends with the start picture being displayed.
The display must show "System status Run".

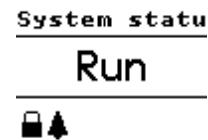

3. Switch to the PC/laptop with the installed JUMO smartWARE Setup program and start the program.
4. Click the "+ New project" button.
The "Select project template" dialog opens.
5. Select project template for the relevant central processing unit and system version and confirm with "OK".
The setup program switches to the project folder.

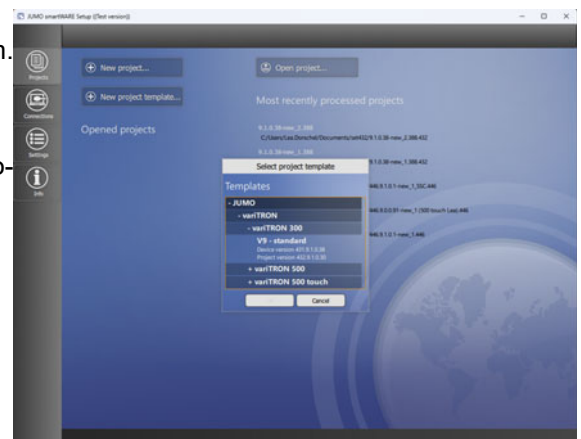

6. Switch to the "Project management" tab.
7. Click the "Save as..." button and save the project under a significant name.
8. Switch to the "HW-Assistent Systembus" tab.
The setup program opens the window HW-Assistent Systembus. The window is separated into 3 areas:- Hardware configuration- System components- Settings
The previously selected central processing unit is shown in the upper area of the "Hardware configuration" area.
9. Click on the "+" symbol at bottom right of the "Hardware configuration" area.
The program adds a virtual DIN rail below.



**NOTE!**

If a central processing unit was connected to an existing bus topology, the hardware arrangement can be loaded with a bus scan (network symbol at the bottom right).

**NOTE!**

The modules can be found in the HW-Assistent Systembus in the "System components" area. They can be used to configure the control system:

- Central processing unit
- Controller
- Relay
- Analog IO units
- Digital IO units
- Router units
- Various; thyristor power controller (JUMO TYA200), adapter plates, end plates

The system components are arranged in drop-down menus and can be arranged on the central processing unit or DIN rail using drag and drop.

A router unit, a JUMO variTRON module from the 7050xx series, or the system module 705171 from the I/O series can be placed as the first module downstream of the central processing unit.

In addition to the components displayed in the HW-Assistent Systembus, compatible third-party components can be included in the control system configuration with the JUMO system bus.

7 Startup

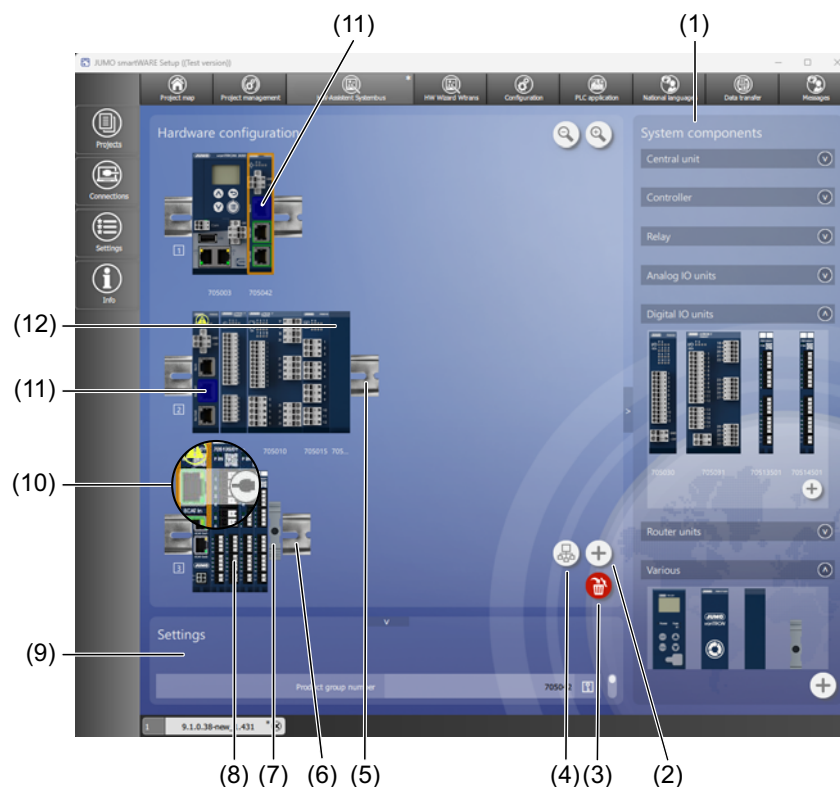

1	System components area	2	"+" add DIN rail button
3	"Delete module" button	4	"Bus scan" button
5	First DIN rail	6	Optional second DIN rail
7	End plate JUMO I/O modules (7051xx)	8	JUMO I/O modules (7051xx)
9	"Settings" area, individual settings for modules	10	Establish system bus connection
11	Already established system bus connection (marked in color)	12	End plate JUMO variTRON

10. Open drop-down menu for router units and drag the desired module onto the DIN rail.

First, a 1-port router module (705043) or 3-port router module (705042) or, if modules from the JUMO I/O series are used, the 3-port router module (70516301) must be used.

Once the module is grabbed with the mouse, the white field displays where it can be placed on the DIN rail.

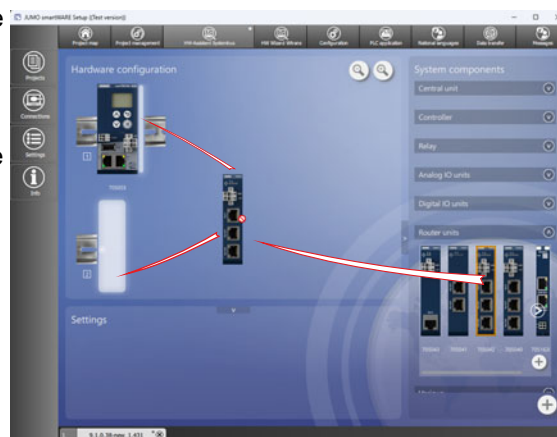

11. Arrange modules on the DIN rail.
If required, select expansion slots of the module in the "Settings" area for controller modules.
12. If required, add additional DIN rail.
See step 11.

13. Establish system bus connection.
14. If required, switch to "HW-Assistent Wtrans".
15. If required, save modified hardware configuration.
16. Drag Wtrans component used on the central processing unit into the dashed border in the "Transmitter configuration" area using drag and drop.

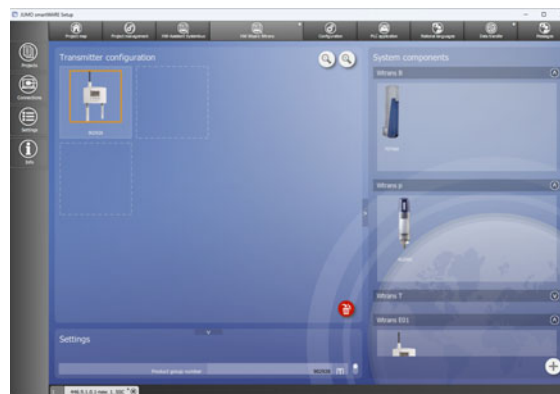

17. Click the "Connections" tab on the left in the program.

The program switches to the connection list.

18. As required, add/change specifications for the designation, description, user (**Master**), host address, and port (**443**).
Confirm changes by clicking "Apply".

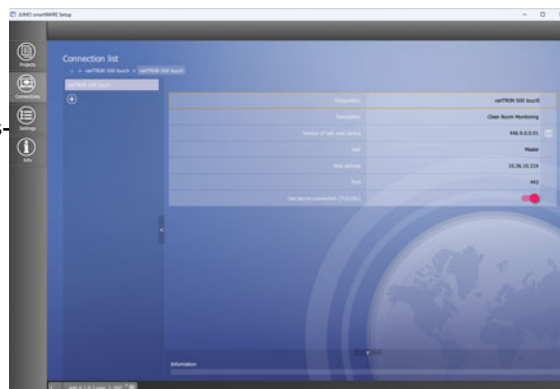

19. Call up project folder and click the "Data transfer" tile.

20. Click the "Connecting..." button.

The setup program connects to the central processing unit.

21. Click the "Send to device" button.

The setup program sends the current configuration to the central processing unit.

22. Check the status LED of all modules.

The status LED will light up steady green as soon as the system bus has the status "Operational".



7 Startup

23. Switch to the "Configuration" tab in the setup program.
- Configure digital and analog inputs and outputs.
 - If necessary, configure the controller function of the controller module (incl. controller parameters).
 - If necessary, configure other functions (e.g., limit value monitoring function, setpoint values).

If setpoint value programs are being used:
Configure central processing unit:

- Configure program generator (Configuration > PLC configuration)
 - Create program (Configuration > Programs)
24. If used, configure Wtrans transmitter (Configuration > Wtrans gateway):
- Select radio frequency.
 - Set transmitter ID and value for wireless timeout.
 - If necessary, set parameters for processing the transmitted measured value (factor, offset, linearization).
25. Optional: Create the CODESYS application
Setup program > PLC application
- Select and apply the appropriate CODESYS version.
 - Start CODESYS.
 - Create the CODESYS application.
26. Optional: Use existing CODESYS application.
Product page: qr-705003-en.jumo.info or [JUMO Software Download Center](#)
- Download "*JUMO variTRON 300Visu template*"



The CODESYS application or the Visu template must match the system version of the device used.

27. Optional: Setting up data recording without using CODESYS
- Setup program > HW-Assistent Systembus:
 - Change module designation if necessary.
 - Setup program > Configuration > Recorder > Groups > Group xx:
 - Assign a meaningful designation for the group.
 - Assign input signals (process values) to the analog and digital channels.
 - Set memory status and memory cycle.



- Setup program > Configuration > Recording data export > Recording data export:
 - Configure and activate connection to the database (Datastore) (condition for data recording).
28. Optional: Setting up data recording using CODESYS
- Setup program > HW-Assistent Systembus:
 - Note the module label.
 - Setup program > Configuration > Recorder > Groups > Group xx:
 - Assign a meaningful designation for the group.
 - Assign input signals (process values; in system version 5 only PLC outputs) to the analog and digital channels.
 - Set memory status and memory cycle.
 - CODESYS application: Connect (map) input signals of the modules with PLC outputs
 - I/O image of the module: Assign the input signal (channel) to a self-created variable.
 - I/O image of the PLC manager: Assign the PLC output (channel) to another self-created variable.
 - Link both variables together in the PLC program (PLC_PRG).
 - If necessary, create a table for documentation, which contains the linked signals (input signal > PLC output).
 - Setup program > Configuration > Recording data export > Recording data export:
 - Configure and activate connection to the database (Datastore) (condition for data recording).
29. After creating the CODESYS application, transfer it to the setup project and close CODESYS if applicable.
30. Transfer the project to the central processing unit:
Setup program > Project > Data transfer
- Send the configuration (incl. CODESYS application) to the central processing unit ("Send to device").



NOTE!

For debugging in the CODESYS application, it is possible to connect "online" to the PLC. In this way, for example, the states of variables can be checked or values can be changed without stopping the application. Before CODESYS is started from the setup program, the option "Start to debug" must be activated. After that, the connection with the PLC can be established in the CODESYS programming environment.

7 Startup

If the CODESYS application is changed while the PLC is running, the "Login with online change" option must be selected in the CODESYS programming environment during transfer. If the change is to be retained in the CPU during power off, the "Update boot application" option must also be activated.



NOTE!

Certain changes made to the configuration (e.g., changes to the hardware configuration) will cause the CPU to restart.

Further information

The JUMO Help Center provides further information, especially on the following topics:

- JUMO Cloud
- JUMO smartWARE SCADA
- JUMO smartWARE Evaluation (as of system version 6)

<https://www.en.helpcenter-jumo.net>

8.1 User rights

8.1.1 System version 7

The information in this chapter applies to system version 7.

User

The following users are created per default:

User name	Password	Assigned role
Master	9200	<ul style="list-style-type: none"> • Administrator • BatchAdmin • ConfigurationRead • ConfigurationWrite • Controller • SystemStatusUi • SystemUi • VisuTemplateAdmin • WebUi
UnregisteredUser This user must not be deleted!		<ul style="list-style-type: none"> • ReadOnly

A user can be edited, and it can also be removed. Likewise, the user's password can also be changed. The function  is used to create a new user.



NOTE!

Due to the restricted possibilities for displaying and entering data on the device display, users with the right "SystemStatusUi" can only be assigned simple passwords. To prevent these passwords from being cracked via the web application, these users must not also be given the right "WebUi".

Roles

The following roles are defined per default:

- Administrator
- ReadOnly (do not delete this role)
- SystemStatusUi (do not delete this role)
- WebUi (do not delete this role)
- SystemUi (do not delete this role)
- ConfigurationRead
- ConfigurationWrite

The following table shows the roles defined per default and the rights they confer (= X).

8 Annex

Administrator	ReadOnly	SystemStatusUi	WebUi	SystemUi	ConfigurationRead	ConfigurationWrite	Right	Description
X							AdvancedSettings	(for future use)
X	X						DeviceInformationRead	Read device information
X							EventlistRead	Read event list
					X		x.Configuration.Read	Read configuration (several single rights)
						X	x.Configuration.Write	Write configuration (several single rights)
X							FirmwareUpdate	Perform a firmware update
X							SystemStateControl	Change the system status
X							BusControl	Change the system bus status (Stop, Start, Reset statistics)
X							CertificateAdministration	Manage certificate
X	X						DebugDataRead	Read debug data
X							DebugInterfaceActivation	Activate SSH interface (only possible on the device)
X							RecorderAdministration	Delete data base
X							AlarmAcknowledgement	Acknowledge alarm
X							DebugDataDelete	Delete debug data
X							EventlistDelete	Delete event list
X							UserManagement	Manage users
X	X						CodesysUi	Visibility of the user in the CODESYS UI
		X					SystemStatusUi	Visibility of the user in the device display (only for JUMO variTRON 300 and 500) When assigning this right, take into account the restricted possibilities for displaying and entering data on the device display (user name, password).
				X			SystemUi	Visibility of the user in the device display (only for JUMO variTRON 500 touch)
			X				WebUi	Logon in the "Web Cockpit" web application

A role can be edited, and it can also be removed.

The function  is used to define a new role

When editing a role, it is also possible to add your own rights (using the "add" function), which can be used in the CODESYS application by means of the "CmpAccessControlManager" library.

8.1.2 System version 8

The specifications in this chapter apply as of system version 8.

User

The following users are created per default:

Username	Password	Assigned role
Master	9200	<ul style="list-style-type: none"> AdministratorRole CodesysUiRole LcdUiRole TftUiRole WebUiRole
User1	1	<ul style="list-style-type: none"> UserRole CodesysUiRole LcdUiRole TftUiRole WebUiRole
Service	9200	<ul style="list-style-type: none"> ServiceDisplayRole CodesysUiRole LcdUiRole TftUiRole WebUiRole
UnregisteredUser This user must not be deleted!		<ul style="list-style-type: none"> ReadOnlyRole

A user can be edited, and it can also be removed. Likewise, the user's password can also be changed.

The  function is used to create a new user.



NOTE!

Due to the restricted possibilities for displaying and entering data on the device display, users with the right "SystemStatusUi" can only be assigned simple passwords. To prevent these passwords from being cracked via the web application, these users must not also be given the right "WebUi".

Roles

The following roles are defined per default:

- AdministratorRole
- UserRole
- ReadOnlyRole (do not delete this role)
- ServiceDisplayRole
- LcdUiRole (previously: SystemStatusUi; do not delete this role)
- TftUiRole (previously: SystemUi); do not delete this role)
- WebUiRole (do not delete this role)
- CodesysUiRole (do not delete this role)

The following tables show the roles defined per default and the rights they confer (= X).

8 Annex

AdministratorRole	UserRole	ReadOnlyRole	ServiceDisplayRole	LcdUIRole	TftUIRole	WebUiRole	CodesysUIRole	Right	Description
X	X							AlarmAcknowledgement	Acknowledge alarm
X			X					BusControl	Change the system bus status (Stop, Start, Reset statistics)
X								CertificateAdministration	Manage certificate
X	X	X	X					ConfigurationRead	Read configuration This right is necessary for the assignment of a special configuration right.
X	X	X	X					ConfigurationWrite	Write configuration This right is necessary for the assignment of a special configuration right.
X	(X)	(X)	(X)					x.Configuration.Read	Read special configuration The special configuration rights are listed in the following table.
X	(X)	(X)	(X)					x.Configuration.Write	Write special configuration The special configuration rights are listed in the following table.
X								DebugDataDelete	Delete debug data
X	X	X	X					DebugDataRead	Read debug data
X			X					DebugInterfaceActivation	Activate SSH interface (only possible on the device)
X	X	X	X					DeviceInformationRead	Read device information
X								EventlistDelete	Delete event list
X	X							EventlistRead	Read event list
X			X					FirmwareUpdate	Perform a firmware update
X								RecorderAdministration	Delete database
X			X					SystemStateControl	Change the system status
X								UserManagement	Manage users
				X				SystemStatusUi	Visibility of the user in the device display (only with JUMO variTRON 300 and 500) When assigning this right, take into account the restricted possibilities for displaying and entering data on the device display (username, password).
					X			SystemUi	Visibility of the user in the device display (only with JUMO variTRON 500 touch)
						X		WebUi	Logging into the "Web Cockpit" web application
							X	CodesysUi	Visibility of the user in the CODESYS UI

Special configuration rights:

AdministratorRole	UserRole	ReadOnlyRole	ServiceDisplayRole	Right	Description
X				AccessControlManager.Configuration.Read	Read settings for users, roles, and rights
X				AccessControlManager.Configuration.Write	Write settings for users, roles, and rights
X	X	X		BatchManager.Configuration.Read	Read settings for batch control
X	X	X		BatchManager.Configuration.Write	Write settings for batch control
X				CertificateHandler.Configuration.Read	Read settings for certificate management (e.g. for Node-RED, HTTPS)
X			X	CertificateHandler.Configuration.Write	Write settings for certificate management (only texts)
X				CloudGatewayBackend.Configuration.Read	Read settings for the connection to the JUMO Cloud
X				CloudGatewayBackend.Configuration.Write	Write settings for the connection to the JUMO Cloud
X	X		X	ConfigurationDataManager.Configuration.Read	Export configuration (e.g. on USB flash drive) or extract in the Web Cockpit
X			X	ConfigurationDataManager.Configuration.Write	Import configuration (e.g. from USB flash drive) or import in the Web Cockpit
X				DataBaseManagement.Configuration.Read	Read settings for recording data export
X				DataBaseManagement.Configuration.Write	Write settings for recording data export
X			X	DebugDataManager.Configuration.Read	Read settings for debug data (only texts)
X			X	DebugDataManager.Configuration.Write	Write settings for debug data (only texts)
X	X	X	X	DeviceManager.Configuration.Read	Read settings for device manager
X	X		X	DeviceManager.Configuration.Write	Write settings for device manager
X	X	X	X	DeviceManager.UnitManagerConfiguration.Read	Read settings for units
X	X		X	DeviceManager.UnitManagerConfiguration.Write	Write settings for units
X				EmailManager.Configuration.Read	Read settings for sending emails
X				EmailManager.Configuration.Write	Write settings for sending emails
X				EtherCatGateway.Configuration.Read	Read settings for system bus
X				EtherCatGateway.Configuration.Write	Write settings for system bus
X				EventlistHandler.Configuration.Read	Read settings for events (only texts)
X				EventlistHandler.Configuration.Write	Write settings for events (only texts)
X				LicenceManager.Configuration.Read	Read settings for licenses (only texts)
X				LicenceManager.Configuration.Write	Write settings for licenses (only texts)
X				NodeRedBackend.Configuration.Read	Read settings for Node-RED
X				NodeRedBackend.Configuration.Write	Write settings for Node-RED
X	X	X	X	PeripheryManager.Configuration.Read	Read settings for Ethernet
X			X	PeripheryManager.Configuration.Write	Write settings for Ethernet
X	X	X	X	PeripheryManager.PortManagement.Read	Read settings for Ethernet port management
X			X	PeripheryManager.PortManagement.Write	Write settings for Ethernet port management

8 Annex

AdministratorRole	UserRole	ReadOnlyRole	ServiceDisplayRole	Right	Description
X				RealTimeScheduler.Configuration.Read	Read settings for real-time processing (e.g. groups)
X				RealTimeScheduler.Configuration.Write	Write settings for real-time processing (e.g. groups)
X				SpsConfigurationManager.Codesys.Read	Read CODESYS application
X				SpsConfigurationManager.Codesys.Write	Write CODESYS application
X				SpsConfigurationManager.Configuration.Read	Read settings for PLC configuration
X				SpsConfigurationManager.Configuration.Write	Write settings for PLC configuration
X				SpsConfigurationManager.Parameter.Read	Read application-specific PLC settings 1 (PLC parameter)
X				SpsConfigurationManager.Parameter.Write	Write application-specific PLC settings 1 (PLC parameter)
X				SpsConfigurationManager.Parameter2.Read	Read application-specific PLC settings 2 (PLC parameter 2)
X				SpsConfigurationManager.Parameter2.Write	Write application-specific PLC settings 2 (PLC parameter 2)
X				SpsConfigurationManager.Parameter3.Read	Read application-specific PLC settings 3 (PLC parameter 3)
X				SpsConfigurationManager.Parameter3.Write	Write application-specific PLC settings 3 (PLC parameter 3)
X				SpsConfigurationManager.Parameter4.Read	Read application-specific PLC settings 4 (PLC parameter 4)
X				SpsConfigurationManager.Parameter4.Write	Write application-specific PLC settings 4 (PLC parameter 4)
X	X			SpsConfigurationManager.Programs.Read	Read settings for programs
X	X			SpsConfigurationManager.Programs.Write	Write settings for programs
X				StorageManager.Configuration.Read	Read settings for data carrier management (network drives)
X				StorageManager.Configuration.Write	Write settings for data carrier management (network drives)
X			X	SystemLogger.Configuration.Read	Read settings for system logger (only texts)
X			X	SystemLogger.Configuration.Write	Write settings for system logger (only texts)
X				SystemObserver.Configuration.Read	Read settings for system monitoring (only texts)
X				SystemObserver.Configuration.Write	Write settings for system monitoring (only texts)
X				SystemStatusManager.Configuration.Read	Read settings for system status manager (only texts)
X				SystemStatusManager.Configuration.Write	Write settings for system status manager (only texts)

AdministratorRole	UserRole	ReadOnlyRole	ServiceDisplayRole	Right	Description
X	X		X	SystemStatusUi.Configuration.Read	Read settings for system status UI (device display); only with devices with LCD display such as JUMO variTRON 300 and 500
X	X		X	SystemStatusUi.Configuration.Write	Write settings for system status UI (device display) (see above)
X		X		SystemUi.Configuration.Read	Read settings for system UI (device screen); only with devices with TFT display such as JUMO variTRON 500 touch
X		X		SystemUi.Configuration.Write	Write settings for system UI (device screen) (see above)
X				SystemUpdateManager.Configuration.Read	Read settings for firmware update (only texts)
X				SystemUpdateManager.Configuration.Write	Write settings for firmware update (only texts)
X				WTransGateway.Configuration.Read	Read settings for Wtrans gateway
X				WTransGateway.Configuration.Write	Write settings for Wtrans gateway
X			X	WebGatewayBackend.Configuration.Read	Read settings for web server
X			X	WebGatewayBackend.Configuration.Write	Write settings for web server

A role can be edited, and it can also be removed.

The function  is used to define a new role.

When editing a role, it is also possible to add your own rights (using the "Add" function), which can be used in the CODESYS application by means of the "CmpAccessControlManager" library.

8 Annex

8.1.3 System version 9

The specifications in this chapter apply as of system version 9.

User

The following users are created per default:

Username	Password	Assigned role
Master	9200	<ul style="list-style-type: none">AdministratorRoleCodesysUiRoleLcdUiRoleTftUiRoleWebUiRole
User1	1	<ul style="list-style-type: none">UserRoleCodesysUiRoleLcdUiRoleTftUiRoleWebUiRole
Service	9200	<ul style="list-style-type: none">ServiceDisplayRoleCodesysUiRoleLcdUiRoleTftUiRoleWebUiRole
UnregisteredUser This user must not be deleted!		<ul style="list-style-type: none">ReadOnlyRole

A user can be edited, and it can also be removed. Likewise, the user's password can also be changed.

The  function is used to create a new user.



NOTE!

Due to the restricted possibilities for displaying and entering data on the device display, users with the right "SystemStatusUi" can only be assigned simple passwords. To prevent these passwords from being cracked via the web application, these users must not also be given the right "WebUi".

Roles

The following roles are defined per default:

- AdministratorRole
- UserRole
- ReadOnlyRole (do not delete this role)
- ServiceDisplayRole
- LcdUiRole (previously: SystemStatusUi; do not delete this role)
- TftUiRole (previously: SystemUi); do not delete this role)
- WebUiRole (do not delete this role)
- CodesysUiRole (do not delete this role)

The following tables show the roles defined per default and the rights they confer (= X).

AdministratorRole	UserRole	ReadOnlyRole	ServiceDisplayRole	LcdUiRole	TftUiRole	WebUiRole	CodesysUiRole	Right	Description
X	X							AlarmAcknowledgement	Acknowledge alarm
X			X					BusControl	Change the system bus status (Stop, Start, Reset statistics)
X								CertificateAdministration	Manage certificate
X	X	X	X					ConfigurationRead	Read configuration This right is necessary for the assignment of a special configuration right.
X	X	X	X					ConfigurationWrite	Write configuration This right is necessary for the assignment of a special configuration right.
X	(X)	(X)	(X)					x.Configuration.Read	Read special configuration The special configuration rights are listed in the following table.
X	(X)	(X)	(X)					x.Configuration.Write	Write special configuration The special configuration rights are listed in the following table.
X								DebugDataDelete	Delete debug data
X	X	X	X					DebugDataRead	Read debug data
X			X					DebugInterfaceActivation	Activate SSH interface (only possible on the device)
X	X	X	X					DeviceInformationRead	Read device information
X								EventlistDelete	Delete event list
X	X							EventlistRead	Read event list
X			X					FirmwareUpdate	Perform a firmware update
X								RecorderAdministration	Delete database
X			X					SystemStateControl	Change the system status
X								UserManagement	Manage users
X								RecorderExportMeasurementValues	Export measurement data
X		X						RecorderViewMeasurementValues	Display measurement data
				X				SystemStatusUi	Visibility of the user in the device display (only with JUMO variTRON 300 and 500) When assigning this right, take into account the restricted possibilities for displaying and entering data on the device display (username, password).
					X			SystemUi	Visibility of the user in the device display (only with JUMO variTRON 500 touch)

8 Annex

AdministratorRole	UserRole	ReadOnlyRole	ServiceDisplayRole	LcdUiRole	TftUiRole	WebUiRole	CodesysUiRole	Right	Description
						X		WebUi	Logon to "Web Cockpit" web application
							X	CodesysUi	Visibility of the user in the CODESYS UI
X								TimeSet	Set the time

Special configuration rights:

AdministratorRole	UserRole	ReadOnlyRole	ServiceDisplayRole	Right	Description
X				AccessControlManager.Configuration.Read	Read settings for users, roles, and rights
X				AccessControlManager.Configuration.Write	Write settings for users, roles, and rights
X	X	X		BatchManager.Configuration.Read	Read settings for batch control
X	X	X		BatchManager.Configuration.Write	Write settings for batch control
X				CertificateHandler.Configuration.Read	Read settings for certificate management (e.g. for Node-RED, HTTPS)
X			X	CertificateHandler.Configuration.Write	Write settings for certificate management (only texts)
X				CloudGatewayBackend.Configuration.Read	Read settings for the connection to the JUMO Cloud
X				CloudGatewayBackend.Configuration.Write	Write settings for the connection to the JUMO Cloud
X				ControlBar.Configuration.Read	Read settings for navigation bar
X				ControlBar.Configuration.Write	Write settings for navigation bar
X	X		X	ConfigurationDataManager.Configuration.Read	Export configuration (e.g. on USB flash drive) or extract in the Web Cockpit
X			X	ConfigurationDataManager.Configuration.Write	Import configuration (e.g. from USB flash drive) or import in the Web Cockpit
X				DataBaseManagement.Configuration.Read	Read settings for recording data export
X				DataBaseManagement.Configuration.Write	Write settings for recording data export
X			X	DebugDataManager.Configuration.Read	Read settings for debug data (only texts)
X			X	DebugDataManager.Configuration.Write	Write settings for debug data (only texts)
X	X	X	X	DeviceManager.Configuration.Read	Read settings for device manager
X	X		X	DeviceManager.Configuration.Write	Write settings for device manager
X	X	X	X	DeviceManager.UnitManagerConfiguration.Read	Read settings for units
X	X		X	DeviceManager.UnitManagerConfiguration.Write	Write settings for units
X				EmailManager.Configuration.Read	Read settings for sending emails
X				EmailManager.Configuration.Write	Write settings for sending emails
X				EtherCatGateway.Configuration.Read	Read settings for system bus
X				EtherCatGateway.Configuration.Write	Write settings for system bus
X				EventlistHandler.Configuration.Read	Read settings for events (only texts)
X				EventlistHandler.Configuration.Write	Write settings for events (only texts)
X				LicenceManager.Configuration.Read	Read settings for licenses (only texts)
X				LicenceManager.Configuration.Write	Write settings for licenses (only texts)
X				NodeRedBackend.Configuration.Read	Read settings for Node-RED
X				NodeRedBackend.Configuration.Write	Write settings for Node-RED
X				PackageManager.Configuration.Read	Read settings for packet manager
X				PackageManager.Configuration.Write	Write settings for packet manager
X	X	X	X	PeripheryManager.Configuration.Read	Read settings for Ethernet

8 Annex

AdministratorRole	UserRole	ReadOnlyRole	ServiceDisplayRole	Right	Description
X			X	PeripheryManager.Configuration.Write	Write settings for Ethernet
X	X	X	X	PeripheryManager.PortManagement.Read	Read settings for Ethernet port management
X			X	PeripheryManager.PortManagement.Write	Write settings for Ethernet port management
X				RealTimeScheduler.Configuration.Read	Read settings for real-time processing (e.g. groups)
X				RealTimeScheduler.Configuration.Write	Write settings for real-time processing (e.g. groups)
X				RealTimeScheduler.RecorderConfiguration.Read	Read settings for recording function
X				RealTimeScheduler.RecorderConfiguration.Write	Write settings for recording function
X				SpsConfigurationManager.Codesys.Read	Read CODESYS application
X				SpsConfigurationManager.Codesys.Write	Write CODESYS application
X				SpsConfigurationManager.Configuration.Read	Read settings for PLC configuration
X				SpsConfigurationManager.Configuration.Write	Write settings for PLC configuration
X				SpsConfigurationManager.Controller.Read	Read settings for software controller
X				SpsConfigurationManager.Controller.Write	Write settings for software controller
X				SpsConfigurationManager.Parameter.Read	Read application-specific PLC settings 1 (PLC parameter)
X				SpsConfigurationManager.Parameter.Write	Write application-specific PLC settings 1 (PLC parameter)
X				SpsConfigurationManager.Parameter2.Read	Read application-specific PLC settings 2 (PLC parameter 2)
X				SpsConfigurationManager.Parameter2.Write	Write application-specific PLC settings 2 (PLC parameter 2)
X				SpsConfigurationManager.Parameter3.Read	Read application-specific PLC settings 3 (PLC parameter 3)
X				SpsConfigurationManager.Parameter3.Write	Write application-specific PLC settings 3 (PLC parameter 3)
X				SpsConfigurationManager.Parameter4.Read	Read application-specific PLC settings 4 (PLC parameter 4)
X				SpsConfigurationManager.Parameter4.Write	Write application-specific PLC settings 4 (PLC parameter 4)
X	X			SpsConfigurationManager.Programs.Read	Read settings for programs
X	X			SpsConfigurationManager.Programs.Write	Write settings for programs
X				StorageManager.Configuration.Read	Read settings for data carrier management (network drives)
X				StorageManager.Configuration.Write	Write settings for data carrier management (network drives)
X				SystemInformationManager.Configuration.Read	Read settings for directory service
X				SystemInformationManager.Configuration.Write	Write settings for directory service

AdministratorRole	UserRole	ReadOnlyRole	ServiceDisplayRole	Right	Description
X			X	SystemLogger.Configuration.Read	Read settings for system logger (only texts)
X			X	SystemLogger.Configuration.Write	Write settings for system logger (only texts)
X				SystemObserver.Configuration.Read	Read settings for system monitoring (only texts)
X				SystemObserver.Configuration.Write	Write settings for system monitoring (only texts)
X				SystemStatusManager.Configuration.Read	Read settings for system status manager (only texts)
X				SystemStatusManager.Configuration.Write	Write settings for system status manager (only texts)
X	X		X	SystemStatusUi.Configuration.Read	Read settings for system status UI (device display); only with devices with LCD display such as JUMO variTRON 300 and 500
X	X		X	SystemStatusUi.Configuration.Write	Write settings for system status UI (device display) (see above)
X		X		SystemUi.Configuration.Read	Read settings for system UI (device screen); only with devices with TFT display such as JUMO variTRON 500 touch
X		X		SystemUi.Configuration.Write	Write settings for system UI (device screen) (see above)
X				SystemUpdateManager.Configuration.Read	Read settings for firmware update (only texts)
X				SystemUpdateManager.Configuration.Write	Write settings for firmware update (only texts)
X				TitleBar.Configuration.Read	Read settings for status bar
X				TitleBar.Configuration.Write	Write settings for status bar
X				UiResourcesProvider.Configuration.Read	Read settings for device resources
X				UiResourcesProvider.Configuration.Write	Write settings for device resources
X				WTransGateway.Configuration.Read	Read settings for Wtrans gateway
X				WTransGateway.Configuration.Write	Write settings for Wtrans gateway
X			X	WebGatewayBackend.Configuration.Read	Read settings for web server
X			X	WebGatewayBackend.Configuration.Write	Write settings for web server

A role can be edited, and it can also be removed.

The function  is used to define a new role.

When editing a role, it is also possible to add your own rights (using the "Add" function), which can be used in the CODESYS application by means of the "CmpAccessControlManager" library.

8 Annex

8.1.4 System version 10

The specifications in this chapter apply as of system version 10.

User

The following users are created per default:

Username	Password	Assigned role
Master	9200	<ul style="list-style-type: none">AdministratorRoleCodesysUiRoleLcdUiRoleTftUiRoleWebUiRole
User1	1	<ul style="list-style-type: none">UserRoleCodesysUiRoleLcdUiRoleTftUiRoleWebUiRole
Service	9200	<ul style="list-style-type: none">ServiceDisplayRoleCodesysUiRoleLcdUiRoleTftUiRoleWebUiRole
UnregisteredUser This user must not be deleted!		<ul style="list-style-type: none">ReadOnlyRole

A user can be edited, and it can also be removed. Likewise, the user's password can also be changed.

The  function is used to create a new user.



NOTE!

Due to the restricted possibilities for displaying and entering data on the device display, users with the right "SystemStatusUi" can only be assigned simple passwords. To prevent these passwords from being cracked via the web application, these users must not also be given the right "WebUi".

Roles

The following roles are defined per default:

- AdministratorRole
- UserRole
- ReadOnlyRole (do not delete this role)
- ServiceDisplayRole
- LcdUiRole (previously: SystemStatusUi; do not delete this role)
- TftUiRole (previously: SystemUi); do not delete this role)
- WebUiRole (do not delete this role)
- CodesysUiRole (do not delete this role)

The following tables show the roles defined per default and the rights they confer (= X).

AdministratorRole	UserRole	ReadOnlyRole	ServiceDisplayRole	LcdUIRole	TftUIRole	WebUIRole	CodesysUIRole	Right	Description
X	X							AlarmAcknowledgement	Acknowledge alarm
X			X					BusControl	Change the system bus status (Stop, Start, Reset statistics)
X								CertificateAdministration	Manage certificate
X	X	X	X					ConfigurationRead	Read configuration This right is necessary for the assignment of a special configuration right.
X	X	X	X					ConfigurationWrite	Write configuration This right is necessary for the assignment of a special configuration right.
X	(X)	(X)	(X)					x.Configuration.Read	Read special configuration The special configuration rights are listed in the following table.
X	(X)	(X)	(X)					x.Configuration.Write	Write special configuration The special configuration rights are listed in the following table.
X								SignClosedBatches	Authorization to sign off batches
X								CurrentBatchManagement	Manage current batches
X								ClosedBatchManagement	Manage closed batches
X								DebugDataDelete	Delete debug data
X	X	X	X					DebugDataRead	Read debug data
X			X					DebugInterfaceActivation	Activate SSH interface (only possible on the device)
X	X	X	X					DeviceInformationRead	Read device information
X								EventlistDelete	Delete event list
X	X							EventlistRead	Read event list
X			X					FirmwareUpdate	Perform a firmware update
X								RecorderAdministration	Delete database
X			X					SystemStateControl	Change the system status
X								UserManagement	Manage users
X								RecorderExportMeasurementValues	Export measurement data
X		X						RecorderViewMeasurementValues	Display measurement data

8 Annex

AdministratorRole	UserRole	ReadOnlyRole	ServiceDisplayRole	LcdUiRole	TftUiRole	WebUiRole	CodesysUiRole	Right	Description
				X				SystemStatusUi	Visibility of the user in the device display (only with JUMO variTRON 300 and 500) When assigning this right, take into account the restricted possibilities for displaying and entering data on the device display (username, password).
					X			SystemUi	Visibility of the user in the device display (only with JUMO variTRON 500 touch)
						X		WebUi	Logon to "Web Cockpit" web application
							X	CodesysUi	Visibility of the user in the CODESYS UI
X								TimeSet	Set the time

Special configuration rights:

AdministratorRole	UserRole	ReadOnlyRole	ServiceDisplayRole	Right	Description
X				AccessControlManager.Configuration.Read	Read settings for users, roles, and rights
X				AccessControlManager.Configuration.Write	Write settings for users, roles, and rights
X	X	X		BatchManager.Configuration.Read	Read settings for batch control
X	X	X		BatchManager.Configuration.Write	Write settings for batch control
X				CertificateHandler.Configuration.Read	Read settings for certificate management (e.g. for Node-RED, HTTPS)
X			X	CertificateHandler.Configuration.Write	Write settings for certificate management (only texts)
X				CloudGatewayBackend.Configuration.Read	Read settings for the connection to the JUMO Cloud
X				CloudGatewayBackend.Configuration.Write	Write settings for the connection to the JUMO Cloud
X				ControlBar.Configuration.Read	Read settings for navigation bar
X				ControlBar.Configuration.Write	Write settings for navigation bar
X	X		X	ConfigurationDataManager.Configuration.Read	Export configuration (e.g. on USB flash drive) or extract in the Web Cockpit
X			X	ConfigurationDataManager.Configuration.Write	Import configuration (e.g. from USB flash drive) or import in the Web Cockpit
X				DataBaseManagement.Configuration.Read	Read settings for recording data export
X				DataBaseManagement.Configuration.Write	Write settings for recording data export
X			X	DebugDataManager.Configuration.Read	Read settings for debug data (only texts)
X			X	DebugDataManager.Configuration.Write	Write settings for debug data (only texts)
X	X	X	X	DeviceManager.Configuration.Read	Read settings for device manager
X	X		X	DeviceManager.Configuration.Write	Write settings for device manager
X	X	X	X	DeviceManager.UnitManagerConfiguration.Read	Read settings for units
X	X		X	DeviceManager.UnitManagerConfiguration.Write	Write settings for units
X				EmailManager.Configuration.Read	Read settings for sending emails
X				EmailManager.Configuration.Write	Write settings for sending emails
X				EtherCatGateway.Configuration.Read	Read settings for system bus
X				EtherCatGateway.Configuration.Write	Write settings for system bus
X				EventlistHandler.Configuration.Read	Read settings for events (only texts)
X				EventlistHandler.Configuration.Write	Write settings for events (only texts)
X				LicenceManager.Configuration.Read	Read settings for licenses (only texts)
X				LicenceManager.Configuration.Write	Write settings for licenses (only texts)
X				NodeRedBackend.Configuration.Read	Read settings for Node-RED
X				NodeRedBackend.Configuration.Write	Write settings for Node-RED
X				PackageManager.Configuration.Read	Read settings for packet manager
X				PackageManager.Configuration.Write	Write settings for packet manager
X	X	X	X	PeripheryManager.Configuration.Read	Read settings for Ethernet

8 Annex

AdministratorRole	UserRole	ReadOnlyRole	ServiceDisplayRole	Right	Description
X			X	PeripheryManager.Configuration.Write	Write settings for Ethernet
X	X	X	X	PeripheryManager.PortManagement.Read	Read settings for Ethernet port management
X			X	PeripheryManager.PortManagement.Write	Write settings for Ethernet port management
X				RealTimeScheduler.Configuration.Read	Read settings for real-time processing (e.g. groups)
X				RealTimeScheduler.Configuration.Write	Write settings for real-time processing (e.g. groups)
X				RealTimeScheduler.RecorderConfiguration.Read	Read settings for recording function
X				RealTimeScheduler.RecorderConfiguration.Write	Write settings for recording function
X				SpsConfigurationManager.Codesys.Read	Read CODESYS application
X				SpsConfigurationManager.Codesys.Write	Write CODESYS application
X				SpsConfigurationManager.Configuration.Read	Read settings for PLC configuration
X				SpsConfigurationManager.Configuration.Write	Write settings for PLC configuration
X				SpsConfigurationManager.Controller.Read	Read settings for software controller
X				SpsConfigurationManager.Controller.Write	Write settings for software controller
X				SpsConfigurationManager.Parameter.Read	Read application-specific PLC settings 1 (PLC parameter)
X				SpsConfigurationManager.Parameter.Write	Write application-specific PLC settings 1 (PLC parameter)
X				SpsConfigurationManager.Parameter2.Read	Read application-specific PLC settings 2 (PLC parameter 2)
X				SpsConfigurationManager.Parameter2.Write	Write application-specific PLC settings 2 (PLC parameter 2)
X				SpsConfigurationManager.Parameter3.Read	Read application-specific PLC settings 3 (PLC parameter 3)
X				SpsConfigurationManager.Parameter3.Write	Write application-specific PLC settings 3 (PLC parameter 3)
X				SpsConfigurationManager.Parameter4.Read	Read application-specific PLC settings 4 (PLC parameter 4)
X				SpsConfigurationManager.Parameter4.Write	Write application-specific PLC settings 4 (PLC parameter 4)
X	X			SpsConfigurationManager.Programs.Read	Read settings for programs
X	X			SpsConfigurationManager.Programs.Write	Write settings for programs
X				StorageManager.Configuration.Read	Read settings for data carrier management (network drives)
X				StorageManager.Configuration.Write	Write settings for data carrier management (network drives)
X				SystemInformationManager.Configuration.Read	Read settings for directory service
X				SystemInformationManager.Configuration.Write	Write settings for directory service

AdministratorRole	UserRole	ReadOnlyRole	ServiceDisplayRole	Right	Description
X			X	SystemLogger.Configuration.Read	Read settings for system logger (only texts)
X			X	SystemLogger.Configuration.Write	Write settings for system logger (only texts)
X				SystemObserver.Configuration.Read	Read settings for system monitoring (only texts)
X				SystemObserver.Configuration.Write	Write settings for system monitoring (only texts)
X				SystemStatusManager.Configuration.Read	Read settings for system status manager (only texts)
X				SystemStatusManager.Configuration.Write	Write settings for system status manager (only texts)
X	X		X	SystemStatusUi.Configuration.Read	Read settings for system status UI (device display); only with devices with LCD display such as JUMO variTRON 300 and 500
X	X		X	SystemStatusUi.Configuration.Write	Write settings for system status UI (device display) (see above)
X		X		SystemUi.Configuration.Read	Read settings for system UI (device screen); only with devices with TFT display such as JUMO variTRON 500 touch
X		X		SystemUi.Configuration.Write	Write settings for system UI (device screen) (see above)
X				SystemUpdateManager.Configuration.Read	Read settings for firmware update (only texts)
X				SystemUpdateManager.Configuration.Write	Write settings for firmware update (only texts)
X				TitleBar.Configuration.Read	Read settings for status bar
X				TitleBar.Configuration.Write	Write settings for status bar
X				UiResourcesProvider.Configuration.Read	Read settings for device resources
X				UiResourcesProvider.Configuration.Write	Write settings for device resources
X				WTransGateway.Configuration.Read	Read settings for Wtrans gateway
X				WTransGateway.Configuration.Write	Write settings for Wtrans gateway
X			X	WebGatewayBackend.Configuration.Read	Read settings for web server
X			X	WebGatewayBackend.Configuration.Write	Write settings for web server

A role can be edited, and it can also be removed.

The function  is used to define a new role.

When editing a role, it is also possible to add your own rights (using the "Add" function), which can be used in the CODESYS application by means of the "CmpAccessControlManager" library.

8 Annex

8.2 Technical data

8.2.1 Interfaces

<p>USB host</p> <p>Designation</p> <p>Type</p> <p>Number</p> <p>Device category</p> <p>Application</p> <p>Data rate</p> <p>Max. current</p>	<p>USB</p> <p>A (socket)</p> <p>1</p> <p>Mass Storage Class, Communications Device Class – Ethernet Control Module (as of system version 8)</p> <p>Connecting a USB flash drive or a USB to Ethernet converter (as of system version 8)</p> <p>Low Speed, Full Speed, Hi-Speed</p> <p>500 mA</p>
<p>Ethernet</p> <p>Designation</p> <p>Type</p> <p>Number</p> <p>Protocol</p> <p>Application</p> <p>Transfer rate</p> <p>Connecting cable</p> <p>Cable length</p>	<p>LAN1, LAN2</p> <p>RJ45</p> <p>2</p> <p>TCP, IPv4, HTTP(S)</p> <p>Via CODESYS as an option: Modbus TCP, PROFINET IO-Controller, EtherCAT Master, OPC UA Server, BACnet/IP, Ethernet/IP (as of system version 10)</p> <p>Communication with:</p> <ul style="list-style-type: none"> - PC (setup program, web browser) - Mail server - Modbus TCP Master/Slave - - PROFINET IO-Device - EtherCAT Slave - OPC UA Client - BACnet/IP Server/Client - JUMO system bus via JUMO variTRON router modules (LAN2 only) <p>10 Mbit/s, 100 Mbit/s</p> <p>Network cable, at least CAT5 (S/FTP)</p> <p>Up to 100 m</p>
<p>RS485 (serial interface)</p> <p>Designation</p> <p>Type</p> <p>Number</p> <p>Application</p> <p>Protocol</p> <p>Data format</p> <p>Transfer rate</p>	<p>Com</p> <p>Removable terminal strip, 2-pole with PUSH IN technology</p> <p>1</p> <p>Fieldbus applications, communication via modem with a PC or with a mail server</p> <p>Via CODESYS: Modbus RTU Master/Slave</p> <p>8/1/n, 8/1/e, 8/1/o</p> <p>9600 Bd, 19200 Bd, 38400 Bd</p>

<p>Wireless interface (optional, as of system version 5)</p>	
<p>Antenna connector</p>	<p>SMA socket</p>
<p>Radio frequency</p>	<p>868.4 MHz (Europe) or 915 MHz (USA, Australia, Canada, New Zealand, etc.)</p>
<p>Open air range</p>	<p>In the 915 MHz frequency band (912.6 MHz to 917.4 MHz) one of 10 fixed frequencies can be set.</p>
<p>Open air range</p>	<p>300 m with 868.4 MHz or 200 m with 915 MHz</p>
<p>Open air range</p>	<p>Range when using the antenna holder for wall mounting with 3 m long antenna cable; when mounting the antenna directly to the receiver, a reduction in the range must be taken into account.</p>
<p>Erforderlicher RSSI value for error-free transmission</p>	<p>> -90 (with stationary transmitter)</p>
<p>Erforderlicher RSSI value for error-free transmission</p>	<p>The RSSI value is an indicator of the strength of the received signal (theoretical value range: -120 to 0).</p>
<p>Application</p>	<p>Receiver for JUMO Wtrans transmitters (wireless measured value transmission)</p>
<p>Compatible transmitters</p>	<p>Wtrans T (902930), Wtrans B (707060), Wtrans p (402060), Wtrans E01 (902928) as of system version 6</p>
<p>Compatible transmitters</p>	<p>Not supported thermocouple types with Wtrans B: MoRe5-MoRe41, W3Re-W26Re</p>

8 Annex

8.2.2 Display

Type	LCD, monochrome
Resolution	96 × 64 pixels (8 rows)

8.2.3 Electrical data

Voltage supply (terminals +24 V and GND) Symbol (see nameplate) Connection	 At the front (removable terminal strip, 2-pole with PUSH IN technology)
Voltage Residual ripple	DC 24 V +25/-20 % SELV 5 %
Current consumption	Max. 280 mA (at DC 19.2 V)
Power consumption	Max. 5.6 W
Conductor cross section on terminals +24 V and GND Wire or stranded wire without ferrule Stranded wire with ferrule 2 × stranded wire with twin ferrule with plastic collar Stripping length	Min. 0.2 mm ² , max. 2.5 mm ² Min. 0.25 mm ² , max. 2.5 mm ² Min. 0.5 mm ² , max. 1.5 mm ² (both stranded wires with identical cross section) 10 mm
Conductor cross section on terminals 1 and 2 (COM) Wire or stranded wire without ferrule Stranded wire with ferrule Stripping length	Min. 0.14 mm ² , max. 1.5 mm ² Without plastic collar: min. 0.25 mm ² , max. 1.5 mm ² With plastic collar: min. 0.25 mm ² , max. 0.5 mm ² 9 mm
Electrical safety	According to DIN EN 61010-1:2020 Overvoltage category III, pollution degree 2
Protection rating	III
Electromagnetic compatibility (EMC) Interference emission Interference immunity	Acc. to DIN EN 61326-1:2022 Class A – only for industrial use – Industrial requirement
Radio frequency spectrum 868.4 MHz 915 MHz (912.6 MHz to 917.4 MHz)	Acc. to ETSI EN 300 220-1 and ETSI EN 300 220-2 Acc. to FCC - Title 47 CFR Part 15 and ANSI C63.4
Buffer battery service life	Typically 6 years (lithium battery) Observe error messages on battery status in the event list (battery almost empty, battery empty)!

8.2.4 Housing and environmental conditions

Case type	Plastic case for DIN rail mounting in the control cabinet (indoor use); DIN rail acc. to DIN EN 60715, 35 mm × 7.5 mm × 1 mm
Dimensions (W × H × D)	45 mm × 101 mm × 101.5 mm (without connection elements)
Weight (fully fitted, incl. antenna)	Approx. 215 g
Protection type	IP20, according to DIN EN 60529
Ambient temperature range	-20 to +55 °C
Storage temperature range	-40 to +70 °C
Resistance to climatic conditions	Relative humidity ? 90 % annual average without condensation (climate class 3K3 acc. to DIN EN 60721-3-3 with extended temperature and humidity range)
Site altitude	Up to 2000 m above sea level
Vibration	Acc. to DIN EN 60068-2-6, table C.2
Amplitude	0.15 mm from 10 to 58.1 Hz
Acceleration	20 m/s ² from 58.1 to 150 Hz
Shock	Acc. to DIN EN 60068-2-27, table A.1
Peak acceleration	150 m/s ²
Shock duration	11 ms

8.2.5 Approval marks and certificates

c UL us	
Test facility	Underwriters Laboratories
Certificate/certification number	E201387
Inspection basis	UL 61010-1 (3. Ed.), CAN/CSA-22.2 No. 61010-1 (3. Ed.)
Valid for	All types
DNV	
Test facility	DNV
Certificate/certification number	TAA000016N
Inspection basis	Class Guideline DNV-CG-0339
Valid for	Type without wireless interface; a power supply unit with DNV type approval is required (e.g. type 705090)

8 Annex

8.3 PLC data

8.3.1 System times

Cycle times

	Typical
Adjustable PLC (task) ^a Adjustable task cycles are not restricted on the device side. If necessary, restrictions on the CODESYS side must be observed (see documentation on CODESYS). Using an external trigger, it is possible to set up a synchronous cycle time with the system bus.	125 ms (default setting when creating an IEC task)
System bus for 7050xx JUMO variTRON Multichannel controller module (705010) Analog input module, 4-channel (705020) Analog input module, 8-channel (705021) Analog output module 4-channel (705025) 7051xx JUMO I/O system Multichannel controller module (705152) Analog input module 4-channel (705113) High-precision thermocouples Universal Current/voltage (high speed) Analog output module 4-channel (705123)	100 ms (default setting, 10 to 1000 ms) (ten times the cycle time value for digital modules)
System bus for 7050xx JUMO variTRON Relay module, 4-channel (705015) Digital input and output module 12-channel (705030) Digital input and output module 32-channel (705031) 7051xx JUMO I/O system Digital input module, 16-channel (705135) Digital output module, 4-channel (705143) Digital output module, 16-channel (705145)	10 ms (default setting, 10 to 1000 ms)

^a Asynchronous with system bus

Sampling rates

	Typical
7050xx JUMO variTRON	
Multichannel controller module ^a (705010)	50 ms
Relay module, 4-channel ^b (705015)	0 ms
Analog input module, 4-channel ^a (705020)	50 ms
Analog input module, 8-channel ^a (705021)	375 ms
Analog output module 4-channel ^a (705025)	20 ms
Digital input and output module 12-channel ^b (705030)	0 ms
Digital input and output module 32-channel ^b (705031)	0 ms
7051xx JUMO I/O system	
Multichannel controller module ^b (705152)	250 ms (50 to 250 ms)
Analog input module, 4-channel ^b (705113)	
High-precision thermocouples	50 ms
Universal	50 ms
Current/voltage (high speed)	12.5 ms
Analog output module 4-channel ^b (705123)	200 ms (for 98% of the setpoint value)
Digital input module, 16-channel ^b (705135)	0 ms
Digital output module, 4-channel ^b (705143)	0 ms
Digital output module, 16-channel ^b (705145)	0 ms

^a Asynchronous with system bus

^b Synchronous with system bus

8 Annex

Module failure detection

The detection of a module failure depends on the maximum configured repetitions and cycle time,
 ⇒ Seite 91.

	Max. repetitions	Cycle time	Typical
7050xx JUMO variTRON Relay module, 4-channel (705015) Digital input and output module 12-channel (705030) Digital input and output module 32-channel (705031) 7051xx JUMO I/O system Digital input module, 16-channel (705135) Digital output module, 4-channel (705143) Digital output module, 16-channel (705145)	5	Task 1: 1 ms	5 ms
7050xx JUMO variTRON Multichannel controller module (705010) Analog input module, 4-channel (705020) Analog input module, 8-channel (705021) 7051xx JUMO I/O system Multichannel controller module (705152) Analog input module 4-channel (705113) High-precision thermocouples Universal Current/voltage (high speed)	5	Task 2: 10 ms	50 ms
7050xx JUMO variTRON Multichannel controller module (705010) Analog output module 4-channel (705025) 7051xx JUMO I/O system Multichannel controller module (705152) Analog output module 4-channel (705123)	5	Task 3: 10 ms	50 ms

Selective response time

The response time is the time needed to transfer information from the sensor to the actuator during fault-free standard operation.

The selective response time relates to responses from the input to the output. Please refer to the table for typical values.

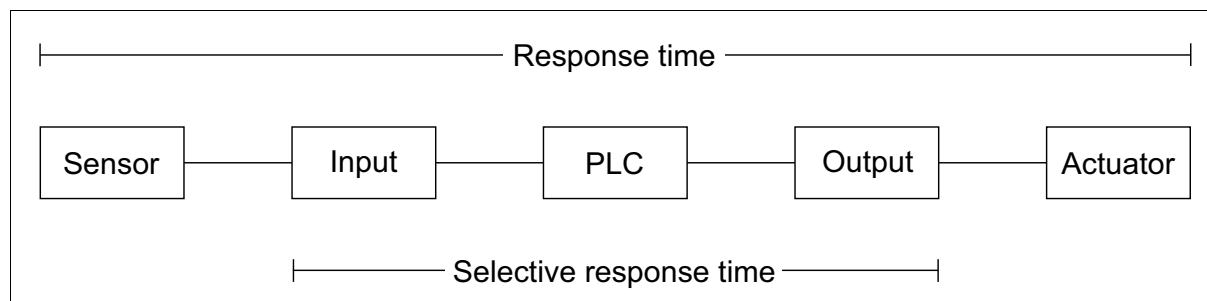

Modules	Typical ^a	Description
Digital input module, 16-channel (705135)	3 ms	Input: Digital input
Digital output module, 4-channel (705143)		Output: Digital output/Relay
Digital output module, 16-channel (705145)		
Analog output module 4-channel (705123)	27 ms	Input: Digital input Output: Analog output
Analog input module 4-channel (705113) High-precision thermocouples Universal	100 ms	Input: Analog input Output: Digital output/Relay
Analog input module 4-channel (705113) Current/voltage (high speed)	30 ms	Input: Analog input Output: Digital output/Relay

^a In the case of analog signals, the time at which a signal level of 80 % is reached is taken into account. The value applies to operation with very low system loads and a low number of modules connected to the system bus. The minimum cycle times are configured for the system bus master (task 1: 1 ms, task 2 and 3: 10 ms).

8.3.2 IEC tasks

Assignment of IEC tasks:

- 0 to 15: RT task
- 6 to 32: Normal priority
- Factory setting: Priority 31

Details are to be found in the CODESYS documentation.



NOTE!

The device does not have an integrated UPS. In case of a power failure, the IEC tasks are not terminated in a defined manner. The retain data is saved regularly as part of the factory boot project (cycle time 1 s). This realization is to be adapted by the user to his requirements. The backup should be realized by a regular synchronization of the data within a CODESYS application. The required cycle time and, if necessary, other parameters must also be defined by the user.

8 Annex

8.3.3 Memory for customer-specific PLC programs

The available memory space for customer-specific PLC programs (program code, data, retain data) is dynamic and depends on how much free memory is available in the device.

The free memory is displayed in the system monitoring (Device info > System monitoring > Memory). However, this memory must not be used completely, as the system will then no longer run stably.

8.4 Buffer battery replacement



CAUTION!

The device contains a buffer battery that is used for data buffering when the device is in switched off mode or if the power fails. The operating life of the battery is typically 6 years. If the battery is low, this is indicated by a fault message in the event list ("Battery almost empty").

Danger of data loss!

- ▶ Replace battery in time.



CAUTION!

Incorrect handling may result in damage or malfunctions.

This compromises the function of the central processing unit or the system as a whole.

- ▶ Only qualified personnel are permitted to replace the buffer battery. The country-specific requirements regarding changes to an electrical device must be observed. Before replacement, the system must be shut down and isolated from the power supply.



CAUTION!

Electronic components may be damaged by electrostatic discharge.

This compromises the function of the central processing unit or the system as a whole.

- ▶ Work may only be carried out at a grounded workstation and in compliance with the relevant safety measures.



NOTE!

Only replace the battery with the following battery type (available from the manufacturer of the device):

Battery manufacturer: RENATA

Type: CR2032 MFR

Temperature range: -30 to +85 °C



WARNING!

Use of an unsuitable battery type

Risk of fire or explosion!

- ▶ Only replace the battery with the battery type specified above.



WARNING!

Improper handling of the battery (lithium button cell)

Risk of fire or explosion!

- ▶ Do not recharge, disassemble or dispose of the battery in a fire.

Shutting down the system

1. Shut down the system and disconnect it from the voltage supply. To do this, loosen the 2 screws of the wired terminal strip +24V/GND and pull the terminal strip forward.
2. If necessary, pull off the wired terminal strip COM toward the front.
3. If necessary, remove other connecting cables (USB, LAN).

8 Annex

Opening the housing

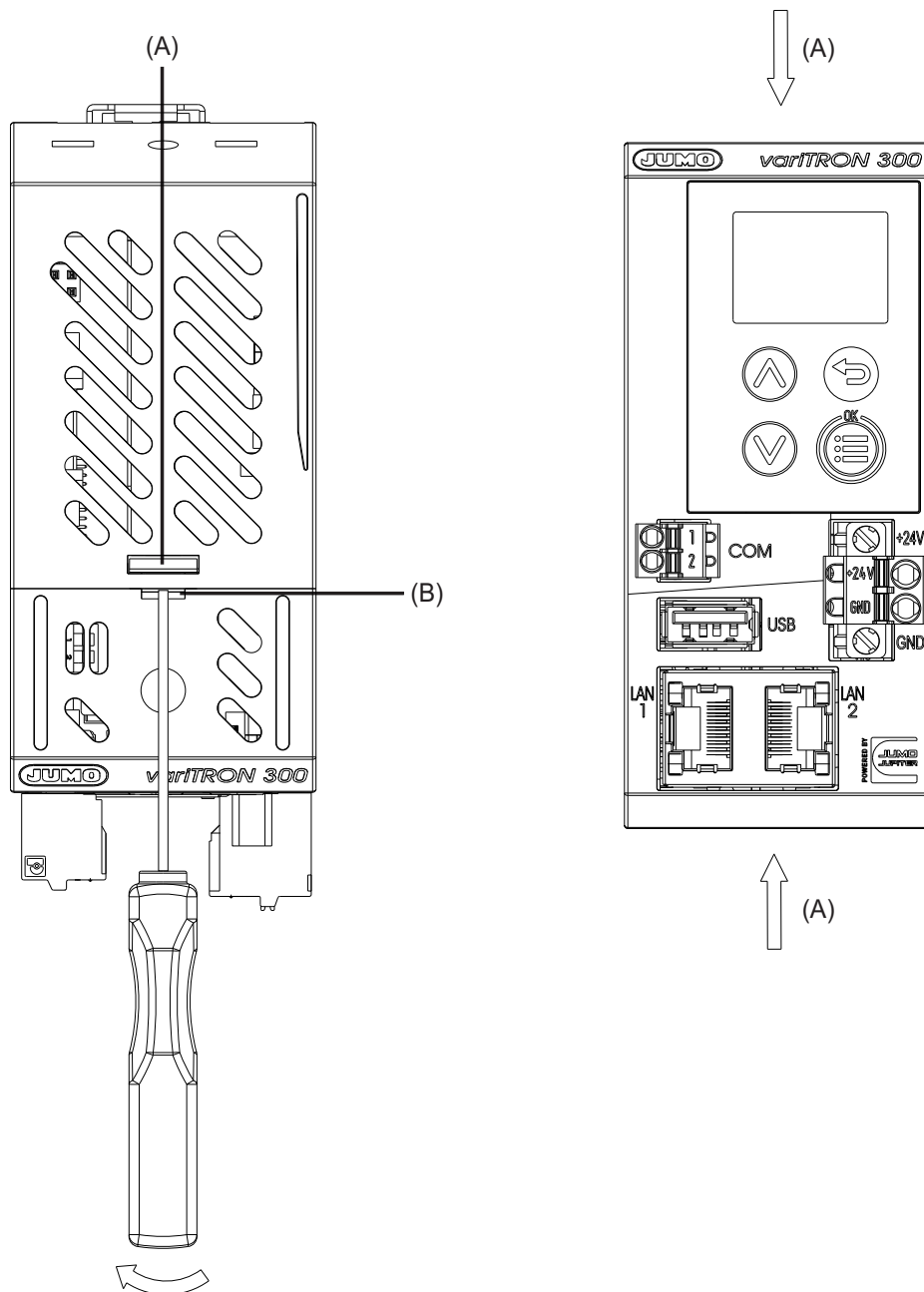

1. If necessary for space reasons, remove the central processing unit from the DIN rail. To do this, please follow the instructions on dismantling previously provided in this document.
2. Loosen both locking hooks (A) one after the other using a screwdriver. To do this, insert the screwdriver into the small slot (B) below the locking hook and turn carefully (maximum 90°). When doing so, pull the housing parts slightly apart so that the locking connections can be released.
3. Pull the front housing section out of the rear housing section.

Replacing the battery

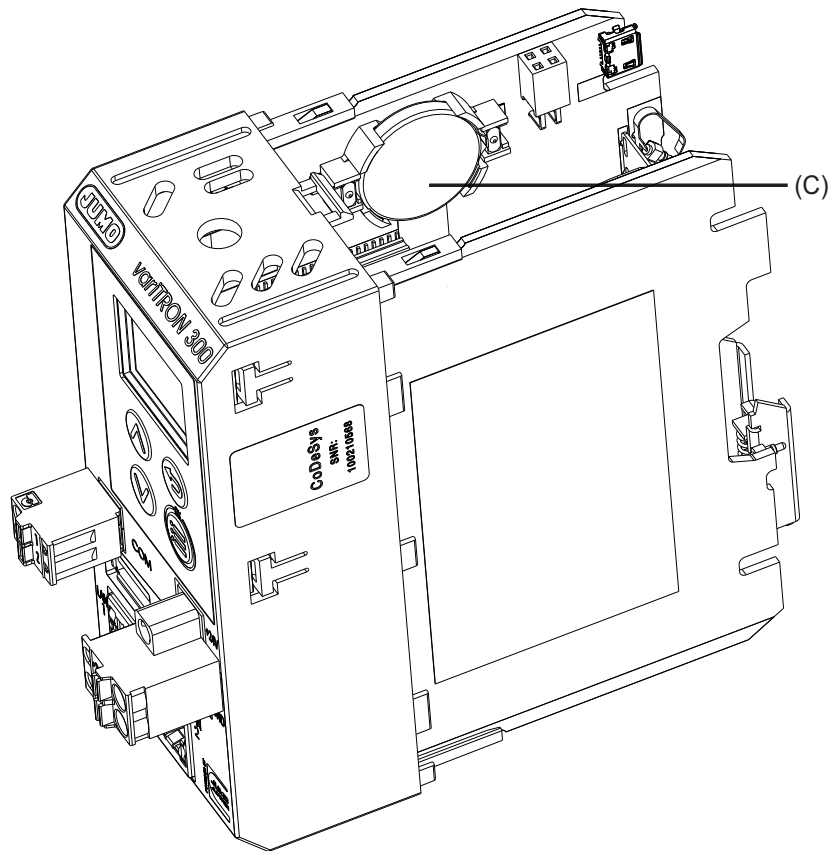

1. Remove the old battery (C) from the holder and replace it with a new one of the same type.

Closing the housing

1. Insert the front housing section into the rear housing section and ensure that both locking hooks engage.
2. If applicable, place the central processing unit back on the top-hat rail. To do this, please follow the instructions on installation previously provided in this document.

Starting up the system again

1. If applicable, connect the connecting cables (USB, LAN).
2. If applicable, attach the wired terminal strip COM.
3. Attach the wired terminal strip +24V/GND and fasten. Start up the system.

8 Annex

8.5 Open-source software

The software of device and/or components of the device was developed using open-source software.

Insofar as the respective applicable license conditions justify a claim to the provision of the source code or other information, JUMO GmbH & Co. KG will provide the source code and the license texts on a conventional data carrier at the costs incurred for the provision of the data carrier.

This offer is valid for three years after the software is made available. If provided for in the license terms, this offer is valid beyond that.

For questions regarding open source software, please contact:

Address JUMO GmbH & Co. KG
License Compliance
Moritz-Juchheim-Straße 1
36039 Fulda, Germany

Email licensecompliance@jumo.net

8.6 China RoHS

 产品组别 Product group: 705003 部件名称 Component Name	产品中有害物质的名称及含量 China EEP Hazardous Substances Information						
	铅 (Pb)	汞 (Hg)	镉 (Cd)	六价铬 (Cr(VI))	多溴联苯 (PBB)	多溴二苯醚 (PBDE)	
外壳 Housing (Gehäuse)	○	○	○	○	○	○	○
过程连接 Process connection (Prozessanschluss)	○	○	○	○	○	○	○
螺母 Nuts (Mutter)	○	○	○	○	○	○	○
螺栓 Screw (Schraube)	○	○	○	○	○	○	○

本表格依据SJ/T 11364的规定编制。
 This table is prepared in accordance with the provisions SJ/T 11364.
 ○：表示该有害物质在该部件所有均质材料中的含量均在GB/T 26572规定的限量要求以下。
 Indicate the hazardous substances in all homogeneous materials' for the part is below the limit of the GB/T 26572.
 x：表示该有害物质至少在该部件的某一均质材料中的含量超出GB/T 26572规定的限量要求。
 Indicate the hazardous substances in at least one homogeneous materials' of the part is exceeded the limit of the GB/T 26572.



JUMO GmbH & Co. KG

Street address:
Moritz-Juchheim-Straße 1
36039 Fulda, Germany

Delivery address:
Mackenrodtstraße 14
36039 Fulda, Germany

Postal address:
36035 Fulda, Germany

Phone: +49 661 6003-0
Fax: +49 661 6003-607
Email: mail@jumo.net
Internet: www.jumo.net

JUMO UK LTD

JUMO House
Temple Bank, Riverway
Harlow, Essex, CM20 2DY, UK

Phone: +44 1279 63 55 33
Fax: +44 1279 62 50 29
Email: sales@jumo.co.uk
Internet: www.jumo.co.uk

JUMO Process Control, Inc.

6724 Joy Road
East Syracuse, NY 13057, USA

Phone: +1 315 437 5866
Fax: +1 315 437 5860
Email: info.us@jumo.net
Internet: www.jumousa.com

